



Husqvarna TC 250/2009

Part. N° 8000H0009 Ed. 02-2009



INFORMAZIONI GENERALI

Il presente catalogo serve per richiedere con esattezza le parti di ricambio

Nelle ordinazioni indicare:

- 1) il numero di codice dei particolari seguito dalla descrizione;
- 2) il colore per i pezzi verniciati o comunque colorati;
- 3) il numero di matricola del motociclo, stampigliato sul canotto di sterzo.

Le indicazioni destra e sinistra si riferiscono ai lati del veicolo rispetto al senso di marcia;

GENERAL INFORMATION

The present spare parts list enables one to order exactly the right spare parts.

When ordering specify:

- 1) the part's code number followed by its description;
- 2) indicate colour for painted or coloured parts;
- 3) the motorcycle's serial number, stamped on the steering head.

References to right and left apply to the vehicle in terms of its direction of movement.

INFORMATIONS GENERALES

Ca catalogue permet de commander correctement les pièces de rechange.

Les commandes doivent être passées en indiquant:

- 1) le numéro de code des pièces détachées suivi de leur description;
- 2) le couleur des pièces peintes ou colorées;
- 3) le matricule de la moto, estampillé sur la tige du guidon.

Droite et gauche sont les côtés du véhicule par rapport au sens de la marche.

ALLGEMEINE HINWEISE

Dieser Ersatzteilkatalog dient zur genauen Angabe der Teile bei Ersatzteilbestellungen.

Bei Ersatzbestellung ist folgendes anzugeben:

- 1) Die Bestellnummer der Ersatzteile mit der entsprechenden Beschreibung;
 - 2) Farbe für lackierte und farbige Teile angeben;
 - 3) Die Sseriennummer des Motorrads, die am Lenkrohr eingepreßt ist.
- Die Angaben rechts und links beziehen sich auf das Fahrzeug in Fahrrihtung.

INFORMACIONES GENERALES

El presente catálogo sirve para pedir con exactitud las partes de recambio.

En los pedidos se debe indicar:

- 1) el número de código de la parte y a continuación la descripción;
- 2) el color para las piezas barnizadas o coloreadas;
- 3) el número de matrícula de la motocicleta, estampado en el tubo de dirección. Las indicaciones derecha e izquierda se refieren a los lados del vehículo respecto del sentido de marcha.

NOTE - LIST - NOTES - NOTE - NOTAS:

- A** : In alternativa - In alternative - En alternative - Wahlweise - En alternativa
C : Modello TC - TC model - Modèle TC - Modell TC - Modelo TC
D : In dotazione - To issue - En necessaire - Ausrüstungsteile - Endotación
E : Ad esaurimento - To fell out - A' finir - Erschöpfung - A agotamiento
F : Fornire assieme - Supply unitedly - Fournir ensemble - Wird zusammen geliefert Equipar juntos
H : Potenziamento per uso sportivo su circuito di gara - Powering for racing use on circuit - Augmentation de la puissance pour usage sportif sur piste - Potenzierung für wettkämpferischen Gebrauch des Motorrad - Aumento de la potencia para uso agonístico sobre circuito de competición
M : Modello SMR- SMR model - Modèle SMR- Modell SMR - Modelo SMR
N : Non fornito - Not supplied - Ne pas fournit - Keine Gellieferende - No equiparado
Ø : Non per JPN - Not for JPN - Ne pas pour JPN - Keine für JPN - No por JPN
P : Non per SMR - Not for SMR - Ne pas pour SMR - Keine für SMR - No por SMR
Q : Solo per SMR / U.S.A. - Only for SMR / U.S.A. - Soulement pour SMR / U.S.A. Nur für SMR / U.S.A. - Solo por SMR / U.S.A.
R : A richiesta - Upon request - Sur demande - Auf anfrage - a pedimento
S : Di serie - Supplied - De série - Standard - De serie
T : Modello TXC- TXC model - Modèle TXC- Modell TXC- Modelo TXC
U : Solo per TE/ U.S.A. - Only for TE/ U.S.A. - Soulement pour TE/ U.S.A. Nur für TE/ U.S.A. - Solo por TE/ U.S.A.
X : Non per U.S.A. - Not for U.S.A. - Ne pas pour U.S.A. - Keine für U.S.A. - No por U.S.A.
XB : Non per BR - Not for BR - Ne pas pour BR - Keine für BR - No por BR
Y : Non per TC - Not for TC - Ne pas pour TC - Keine für TC - No por TC
W : Modello TE- TE model - Modèle TE- Modell TE- Modelo TE
Z : n° denti, number of teeth, numéro dents, Zähne nummer - número dientes

- A** : Austria, Austria, Autriche, Österreich, Austria
AUS : Australia, Australia, Australie, Australien, Australia
B : Belgio, Belgium, Belgique, Belgien, Bélgica
BR : Brasile, Brazil, Brasile, Brasilien, Brasil
CDN : Canada, Canada, Canada, Kanada, Canadá
CH : Svizzera, Switzerland, Suisse, Schweizer, Suiza
D : Germania, Germany, Allemagne, Deutschland, Alemania
E : Spagna, Spain, Espagne, Spanien, España
F : Francia, France, France, Frankreich, Francia
GB : Gran Bretagna, Great Britain, Grand Bretagne, Groos Britan, Gran Bretaña
I : Italia, Italy, Italie, Italien, Italia
J : Giappone, Japan, Japon, Japan, Japón
SF : Finlandia, Finald, Finlande, Finnland, Finlandia
USA : Stati Uniti d'America, United States of America, Etats Units d'Amerique, Vereinigte Staaten von Amerika, Estados Unidos

Dati indicativi soggetti a modifiche senza impegno di preavviso.

All data are subject to modification without prior notice.

Données indicatif sujet au modifications sans obligation de préavis.

Anderungen Vorbehalten.

Datos indicativos sujetos a modificaciones sin compromiso de preaviso.

N° DI MATRICOLA INIZIALE - INITIAL SERIAL NUMBER - MATRICULE INITIAL - BEGINNTESEERIENNUMMER - MATRICULA INICIAL	
MODELLO - MODEL MODELE - MODELL MODELO	MATRICOLA - SERIAL NUMBER MATRICULE - SERIENNUMMER MATRICULA
TC 250	ZKHA300AA9V000001
TC 250/USA	ZKHTC250*9V000001

Codice colore **G**: versione "ROSSO - BIANCO - NERO"
 Color code **G**: "RED - WHITE - BLACK" version
 Code couleur **G**: version "ROUGE - BLANC - NOIR"
 Code Farbe **G**: "ROT - WEISSE - SCHWARZ" Version
 Código de color **G**: moto "ROJO - BLANCO - NEGRO"

Tavola Drawing Table Bild Tabla	Denominazione	Description	Designation	Bezeichnung	Denominacion	Pagina Page Seite Paja
1	ATTREZZI DI ASSISTENZA, MANUALI E CATALOGHI	SERVICE TOOLS, MANUALS AND CATALOGS	OUTILS D'ASSISTANCE, MANUELS ET CATALOGUES	HILFAUSRÜSTUNG, HANDBUCH UND KATALOG	HERRAMIENTAS DE ASISTENCIA, MANUALES Y CATALOGOS	13
2	CILINDRO, PISTONE	CYLINDER, PISTON	CYLINDRE, PISTON	ZYLINDER, KOLBEN	CILINDRO, PISTON	15
3	TESTA CILINDRO	CYLINDER HEAD	CULASSE	ZYLINDERKOPF	CULATA	17
4	MANOVELLISMO	CRANKSHAFT	VILEBREQUIN	KURBELWELLE	CIGÜEÑAL	21
5	TRASMISSIONE PRIMARIA, FRIZIONE	PRIMARY DRIVE, CLUTCH	TRANSMISSION PRIMAIRE, EMBRAYAGE	PRIMÄRÜBERSETZUNG, KUPPLUNG	TRANSMISION PRIMARIA, EMBRAGUE	23
6	DISTRIBUZIONE	VALVE TIMING	DISTRIBUTION	VENTILSTEUERUNG	DISTRIBUCION	25
7	SEMICARTER SINISTRO	L.H. HALF CRANKCASE	CARTER G.	GEHAUSEDECKELL.	BANCADA IZQ.	27
8	SEMICARTER DESTRO	R.H. HALF CRANKCASE	CARTER D.	GEHAUSEDECKEL R.	BANCADA DER.	29
9	COPERCHI SEMICARTER DX	R.H. HALF CRANKCASE COVERS	COUVERCLES CARTER D.	GEHAUSEDECKEL R.	TAPAS BANCADA DER.	31
10	COPERCHI SEMICARTER SX	L.H. HALF CRANKCASE COVERS	COUVERCLES CARTER G.	GEHAUSEDECKELL.	TAPAS BANCADA IZQ.	33
11	LUBRIFICAZIONE	OIL PUMP	PUMPEHUILE	MOTORSCHMIERUNG	LUBRICACION	35
12	IMPIANTO ELETTRICO	ELECTRICAL SYSTEM	INSTALLATION ELECTRIQUE	ELEKTRISCHE ANLAGE	PARTE ELECTRICA	37
13	AVVIAMENTO	STARTING	DEMARRAGE	ANLASSER	ARRANQUE	39
14	COMANDO CAMBIO	GEARSHIFT MECHANISM	COMMANDE DE VITESSE	GANGSCHALTUNG	MANDO CAMBIO	41
15	CAMBIO VELOCITA'	GEARBOX	BOITE VITESSES	ZAHNRADGETRIEBE	CAJA CAMBIO	45
16	CARBURATORE	CARBURETTOR	CARBURATEUR	VERGASER	CARBURADOR	49
17	POMPA ACQUA	WATER PUMP	POMPEEAU	WASSERPUMPE	BOMBA AGUA	53
18	IMPIANTO DI RAFFREDDAMENTO	COOLING SYSTEM	INSTALLATION RAFROIDISSEMENT	SCHMIERUNGSSYSTEM	EQUIPO DE ENFRIAMIENTO	55
19	ASPIRAZIONE E FILTRO ARIA	AIR BOX AND FILTER	ASPIRATION ET FILTRE AIRE	ANSAUGEN UND LUFTFILTER	ASPIRATION Y FILTRO DE AIRE	57
20	TELAIO, PEDANE	FRAME, FOOT RESTS	CADRE, REPOSE PIEDS	RAHMEN, FUSSBRETT	BASTIDOR, REPOSAPIES	59
21	SOSPENSIONE ANTERIORE	FRONT FORK ASSEMBLY	SUSPENSION AVANT	VORDERTELESKOPIGABEL	SUSPENSION DELANTERA	61
22	FORCELLONE POSTERIORE	REAR SWING ARM	FOURCHE ARRIERE	HINTERGABEL	HORQUILLA TRASERA	67
23	AMMORTIZZATORE POSTERIORE	REAR SUSPENSION	SUSPENSION ARRIERE	HINTERHAUFHANGUNG	SUSPENSION TRASERA	69
24	LEVRAGGI SOSPENSIONI POSTERIORE	REAR SUSPENSION LINKAGE	LEVIER SUSPENSION ARRIERE	HEBELWERK HINTERHAUFHANGUNG	PALANCA SUSPENSION TRASERA	71
25	MANUBRIO E COMANDI	HANDLEBAR AND CONTROLS	GUIDON ET COMMANDES	LENKER UND STEUERORGANE	MANILLAR Y MANDOS	73
26	FRENO IDRAULICO POSTERIORE	REAR HYDRAULIC BRAKE	FREIN HYDRAULIQUE ARRIERE	HINTERBREMSE	FRENO HIDRAULICO TRASERO	75
27	PANNELLI, PARAFANGHI, SELLA	PANEL, FENDERS, SEAT,	PANNEAU, GARDE-BOUES, SIEGE,	STREIFEN, KOTFLUGEL, SATTEL	PANELO, GUARDABARROS, SILLIN	77
28	SERBATOIO CARBURANTE, CONVOGIATORI	GAS TANK, PANEL	RESERVOIR CARBURANT, FLANC	KRAFTSTOFFBEHALTER, FLANKE	DEPOSITO GASOLINA, LATERAL	79
29	SCARICO	EXHAUST SYSTEM	TUYAU D'ECHAPPEMENT	AUSPUFFROHR	TUBO DE ESCAPE	81
30	FRENO IDRAULICO ANTERIORE	FRONT HYDRAULIC BRAKE	FREIN HYDRAULIQUE AVANT	VORDERBREMSE	FRENO HIDRAULICO DELANTERO	83
31	RUOTA ANTERIORE	FRONT WHEEL	ROUE AV.	VORTERRAD	RUEDA DELANTERA	85

Tavola - Drawing - Table - Bild - Tabla

1

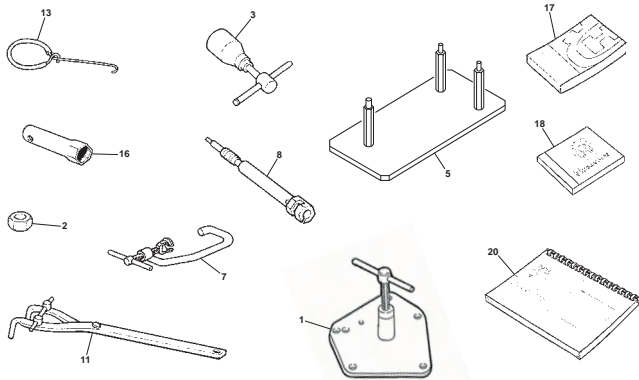

Pagina - Page - Page - Seite - Paja

12

Tavola - Drawing - Table - Bild - Tabla

2

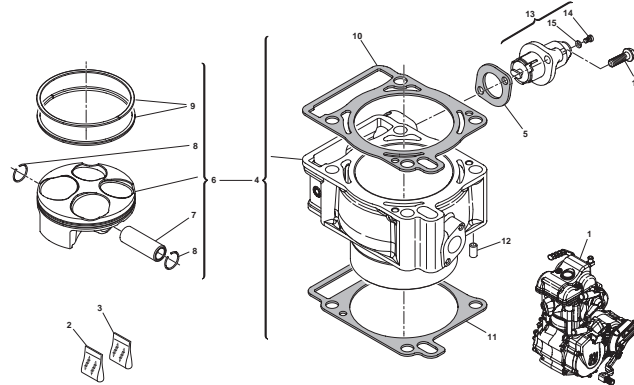

Pagina - Page - Page - Seite - Paja

14

Tavola - Drawing - Table - Bild - Tabla

3

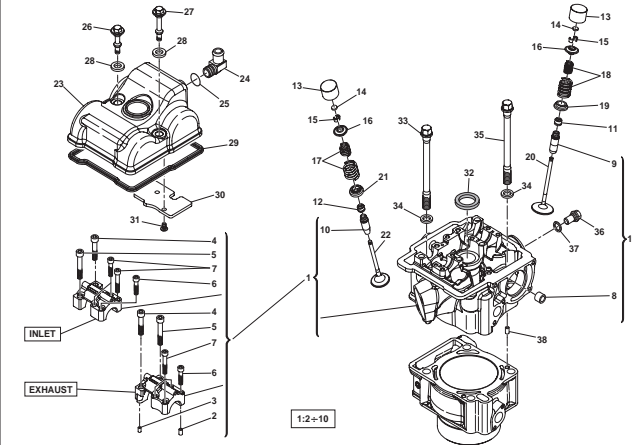

Pagina - Page - Page - Seite - Paja

16

Tavola - Drawing - Table - Bild - Tabla

4

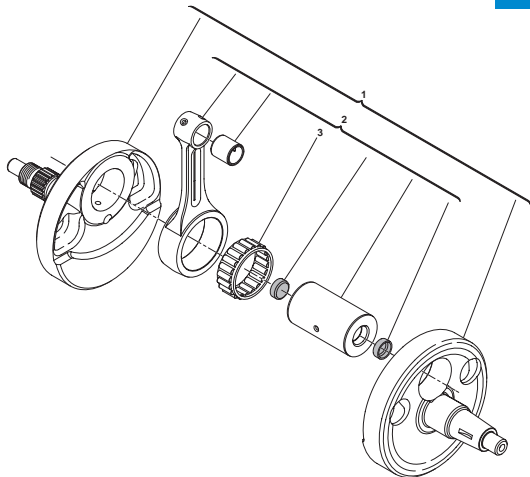

Pagina - Page - Page - Seite - Paja

20

Tavola - Drawing - Table - Bild - Tabla

5

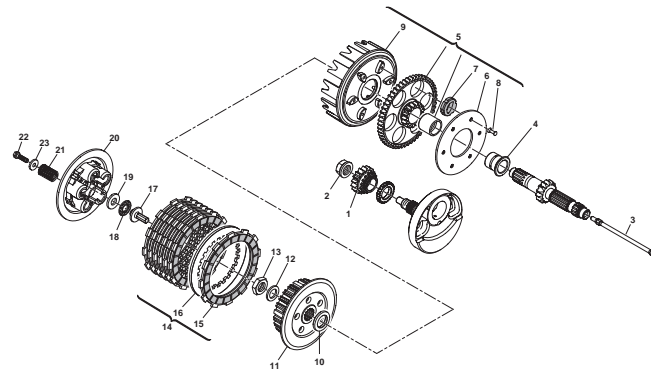

Pagina - Page - Page - Seite - Paja

22

Tavola - Drawing - Table - Bild - Tabla

6

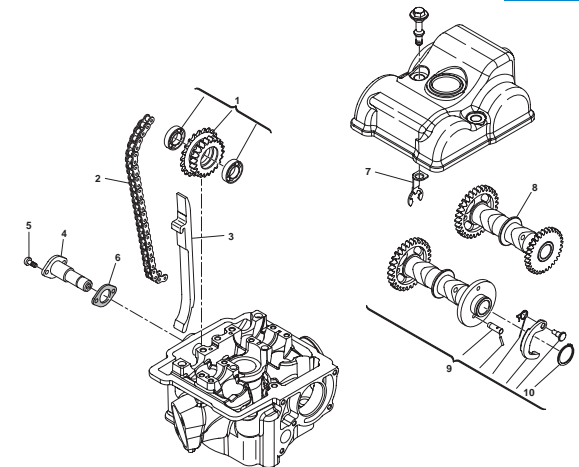

Pagina - Page - Page - Seite - Paja

24

Tavola - Drawing - Table - Bild - Tabla

7

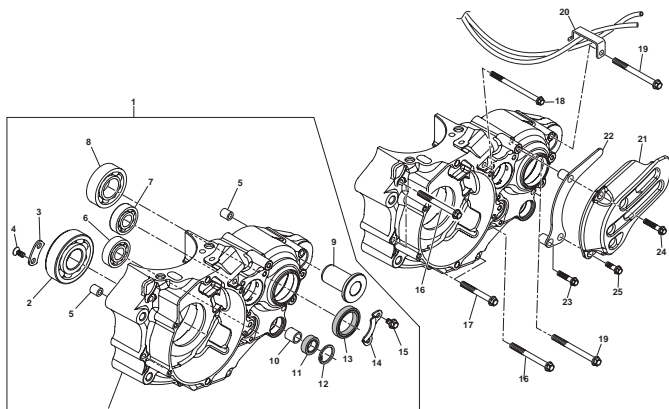

Pagina - Page - Page - Seite - Paja

26

Tavola - Drawing - Table - Bild - Tabla

8

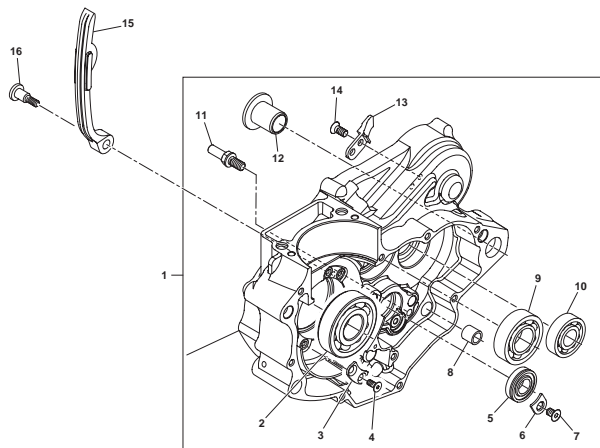

Pagina - Page - Page - Seite - Paja

28

Tavola - Drawing - Table - Bild - Tabla

9

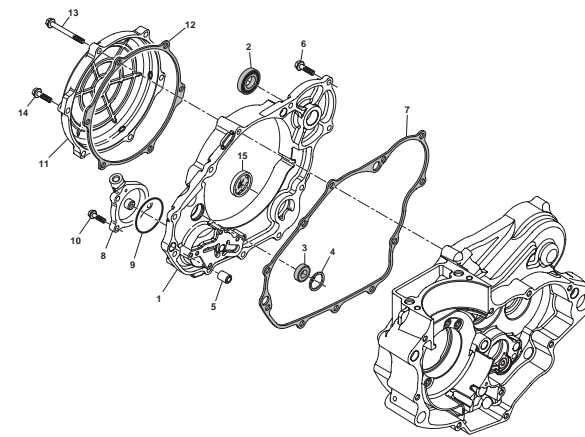

Pagina - Page - Page - Seite - Paja

30

Tavola - Drawing - Table - Bild - Tabla

10

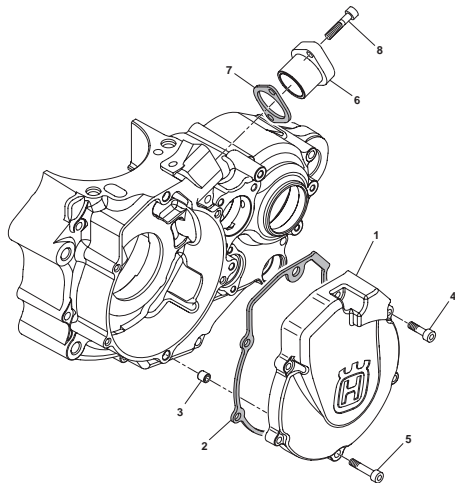

Pagina - Page - Page - Seite - Paja

32

Tavola - Drawing - Table - Bild - Tabla

11

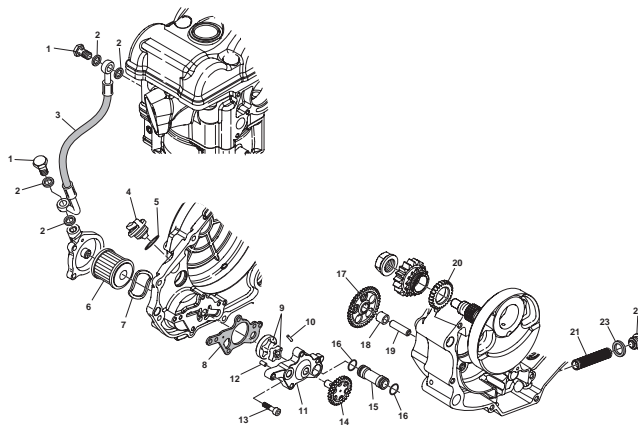

Pagina - Page - Page - Seite - Paja

34

Tavola - Drawing - Table - Bild - Tabla

12

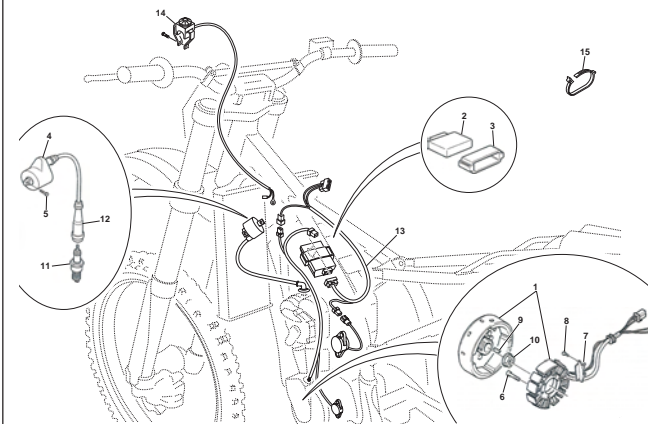

Pagina - Page - Page - Seite - Paja

36

Tavola - Drawing - Table - Bild - Tabla

13

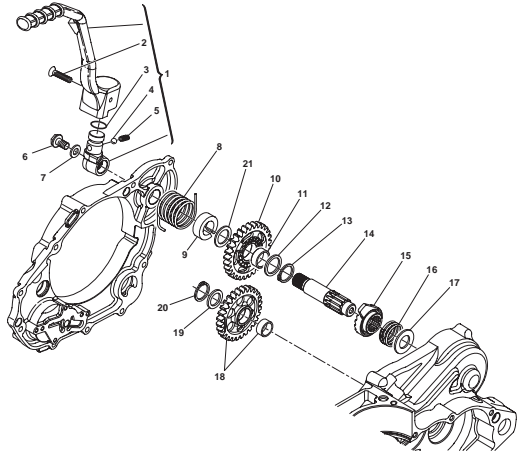

Pagina - Page - Page - Seite - Paja

38

Tavola - Drawing - Table - Bild - Tabla

14

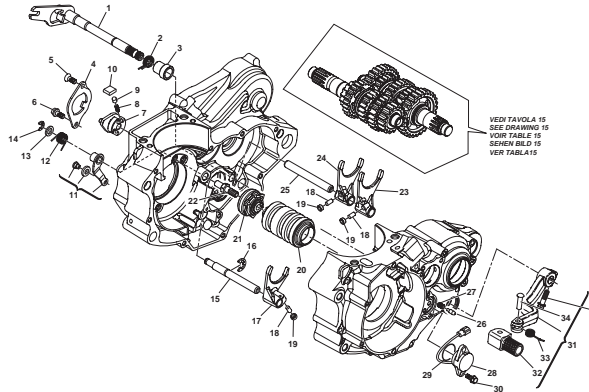

Pagina - Page - Page - Seite - Paja

40

Tavola - Drawing - Table - Bild - Tabla

15

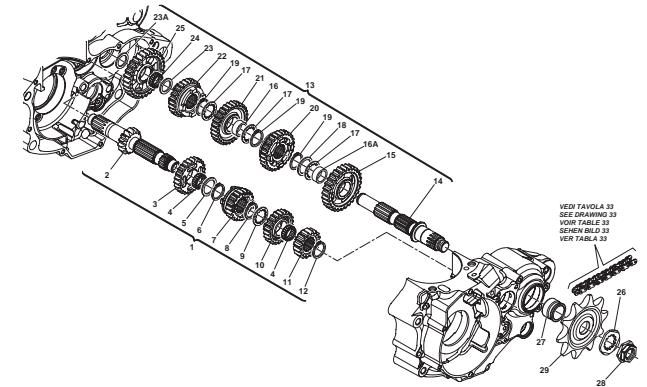

Pagina - Page - Page - Seite - Paja

44

Tavola - Drawing - Table - Bild - Tabla

16

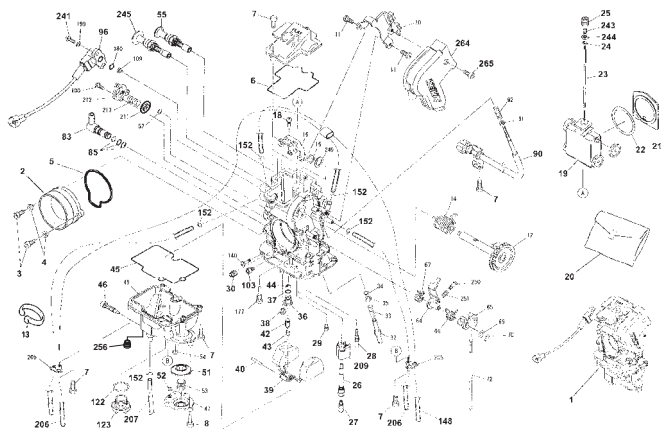

Pagina - Page - Page - Seite - Paja

48

Tavola - Drawing - Table - Bild - Tabla

17

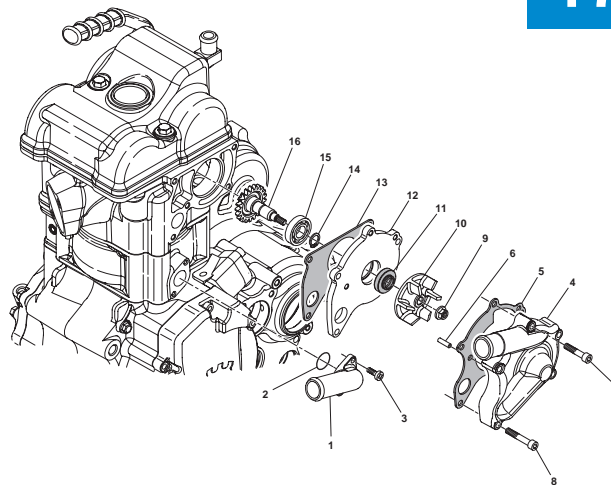

Pagina - Page - Page - Seite - Paja

52

Tavola - Drawing - Table - Bild - Tabla

18

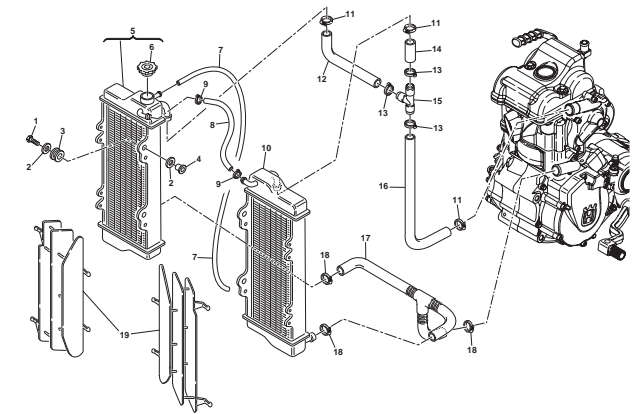

Pagina - Page - Page - Seite - Paja

54

Tavola - Drawing - Table - Bild - Tabla

19

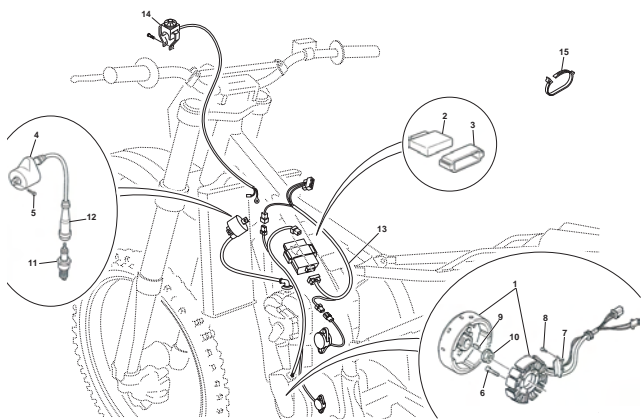

Pagina - Page - Page - Seite - Paja

56

Tavola - Drawing - Table - Bild - Tabla

20

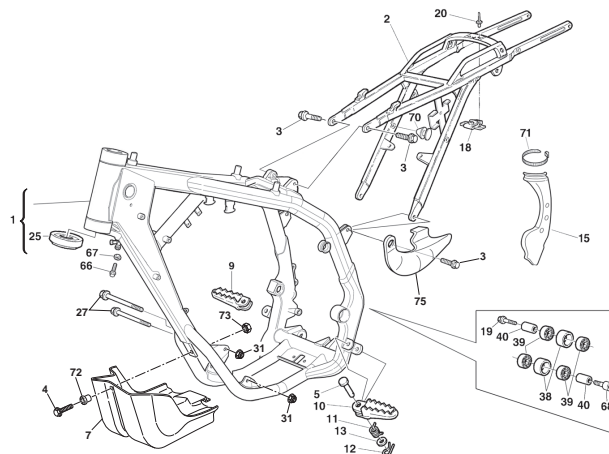

Pagina - Page - Page - Seite - Paja

58

Tavola - Drawing - Table - Bild - Tabla

21

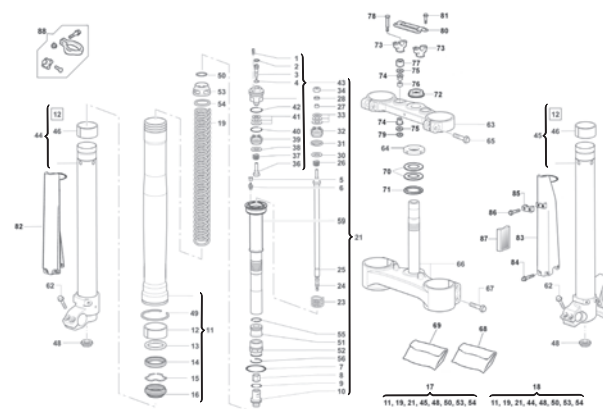

Pagina - Page - Page - Seite - Paja

60

Tavola - Drawing - Table - Bild - Tabla

22

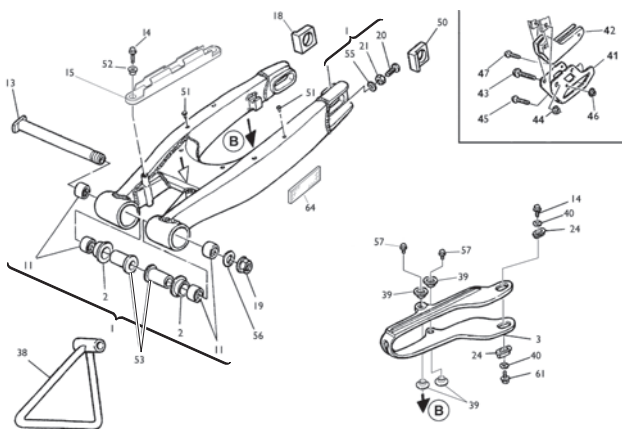

Pagina - Page - Page - Seite - Paja

66

Tavola - Drawing - Table - Bild - Tabla

23

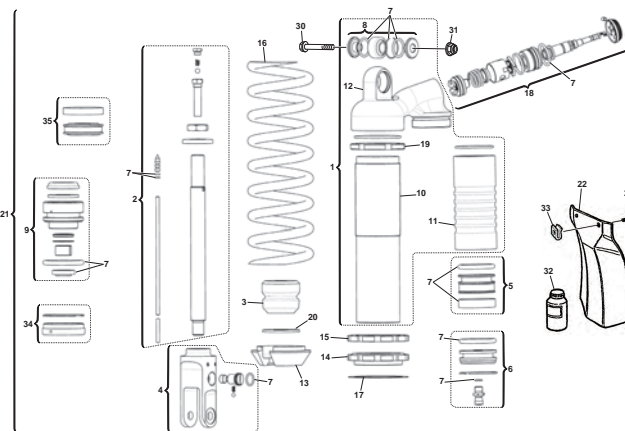

Pagina - Page - Page - Seite - Paja

68

Tavola - Drawing - Table - Bild - Tabla

24

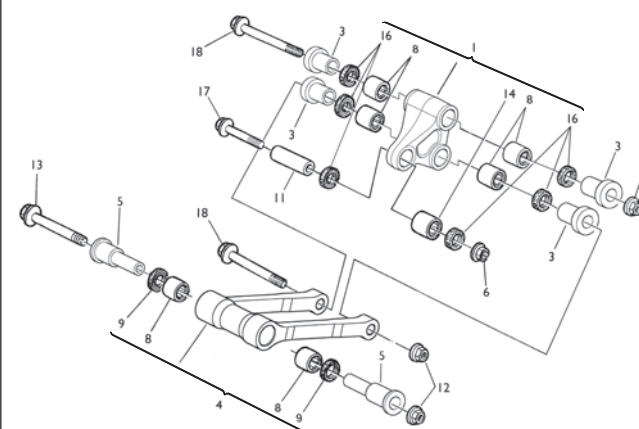

Pagina - Page - Page - Seite - Paja

70

Tavola - Drawing - Table - Bild - Tabla

25

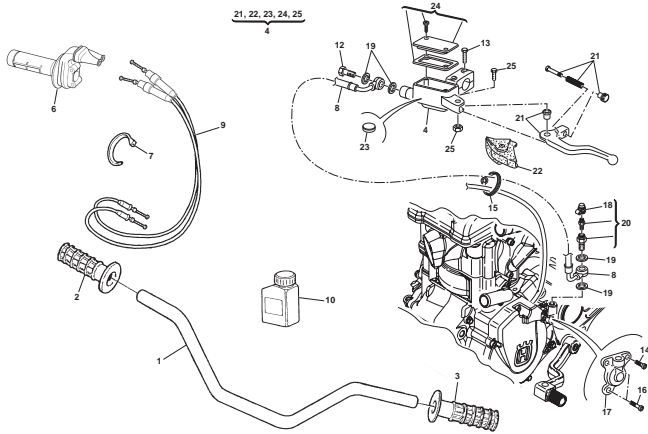

Pagina - Page - Page - Seite - Paja

72

Tavola - Drawing - Table - Bild - Tabla

26

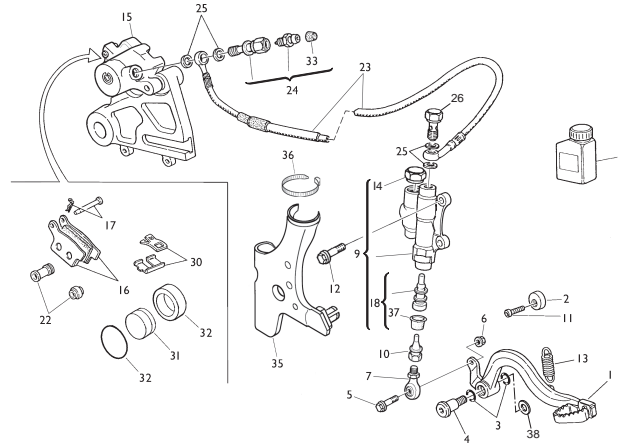

Pagina - Page - Page - Seite - Paja

74

Tavola - Drawing - Table - Bild - Tabla

27

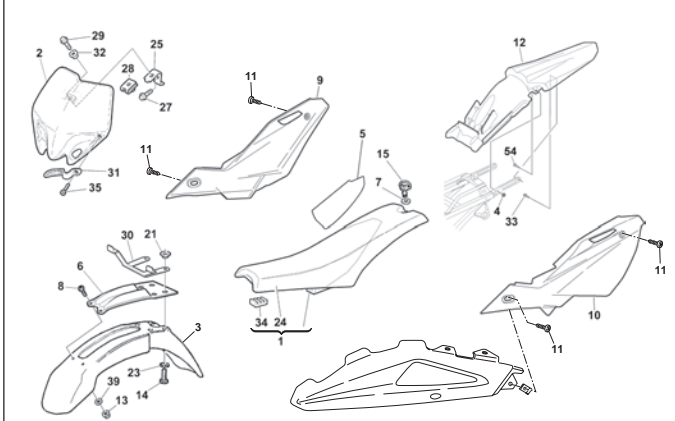

Pagina - Page - Page - Seite - Paja

76

Tavola - Drawing - Table - Bild - Tabla

28

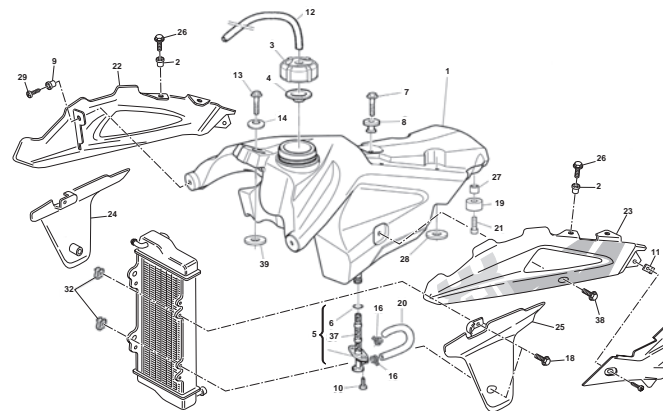

Pagina - Page - Page - Seite - Paja

78

Tavola - Drawing - Table - Bild - Tabla

29

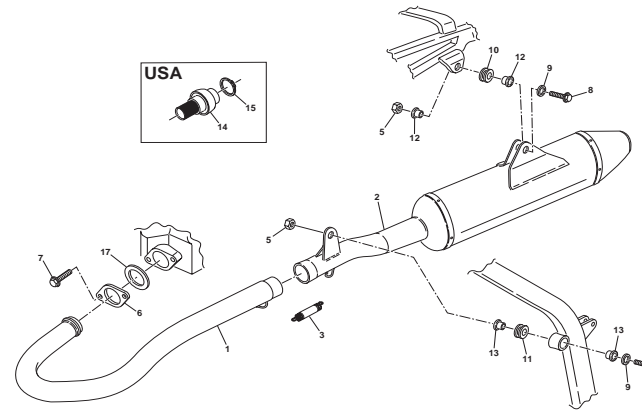

Pagina - Page - Page - Seite - Paja

80

Tavola - Drawing - Table - Bild - Tabla

30

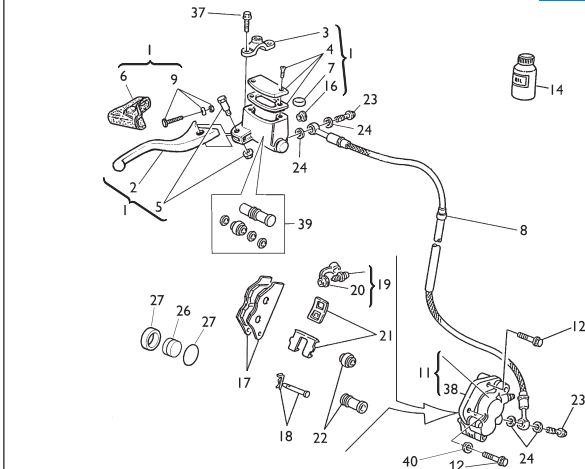

Pagina - Page - Page - Seite - Paja

82

Tavola - Drawing - Table - Bild - Tabla

31

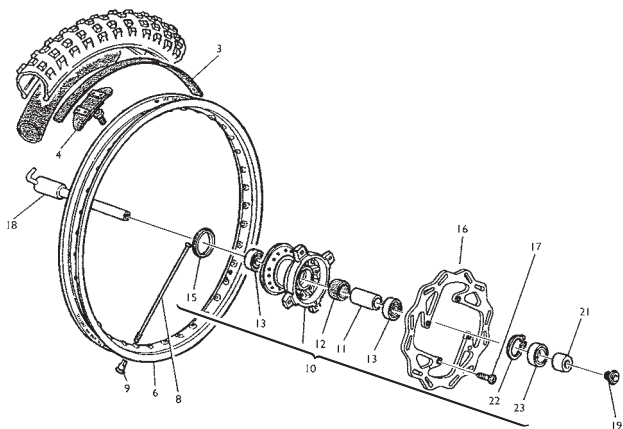

Pagina - Page - Page - Seite - Paja

84

Tavola - Drawing - Table - Bild - Tabla

Pagina - Page - Page - Seite - Paja

Tavola - Drawing - Table - Bild - Tabla

32

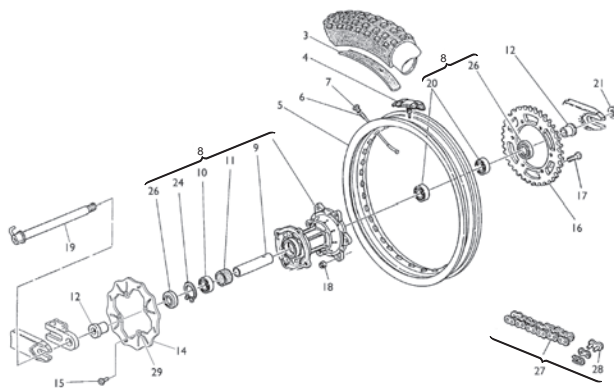

Pagina - Page - Page - Seite - Paja

86

Tavola - Drawing - Table - Bild - Tabla

Pagina - Page - Page - Seite - Paja

Tavola - Drawing - Table - Bild - Tabla

33

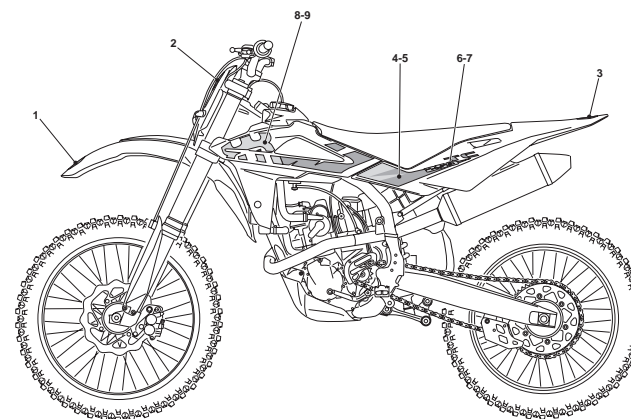

Pagina - Page - Page - Seite - Paja

88

Tavola - Drawing - Table - Bild - Tabla

Pagina - Page - Page - Seite - Paja

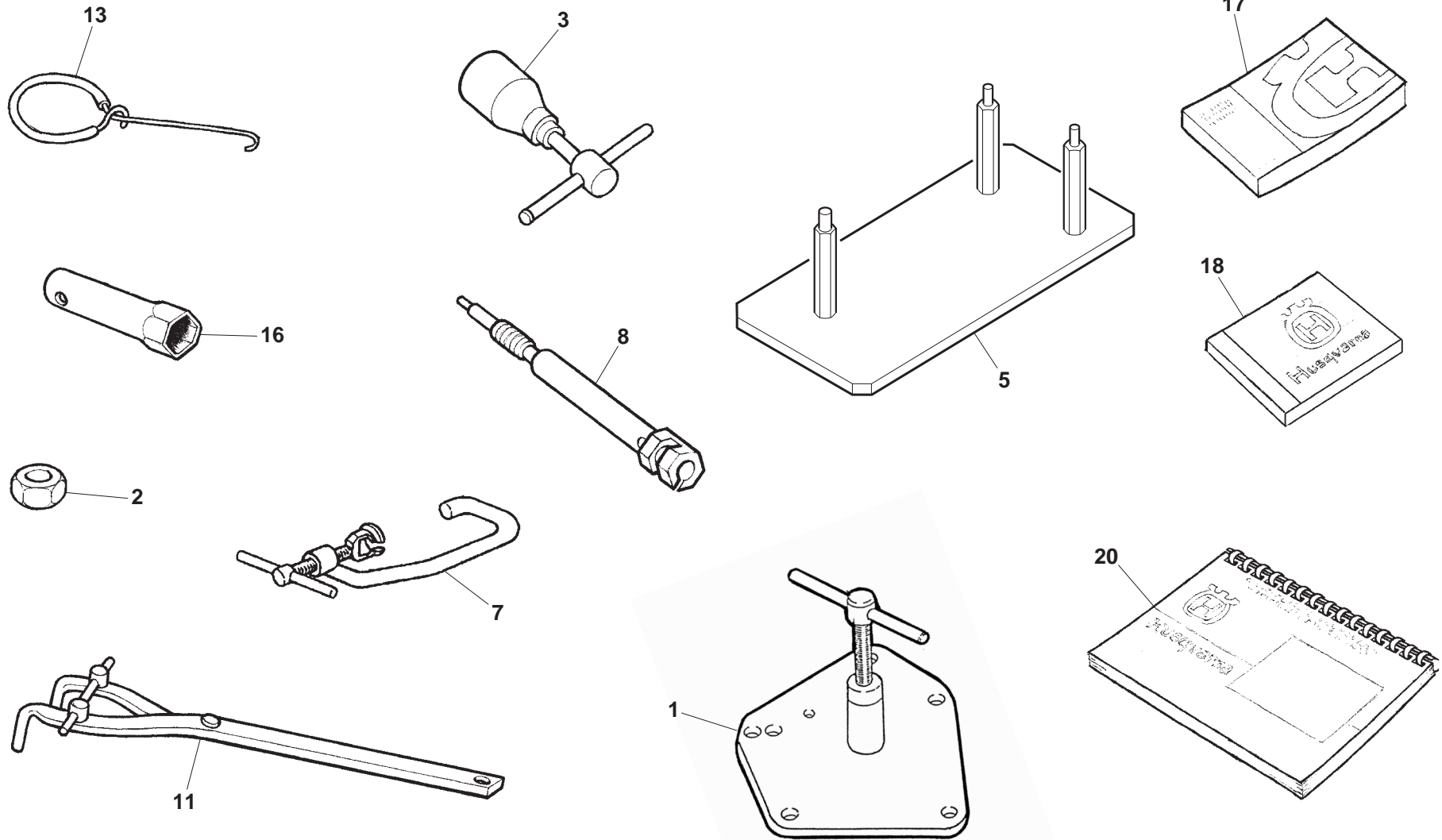

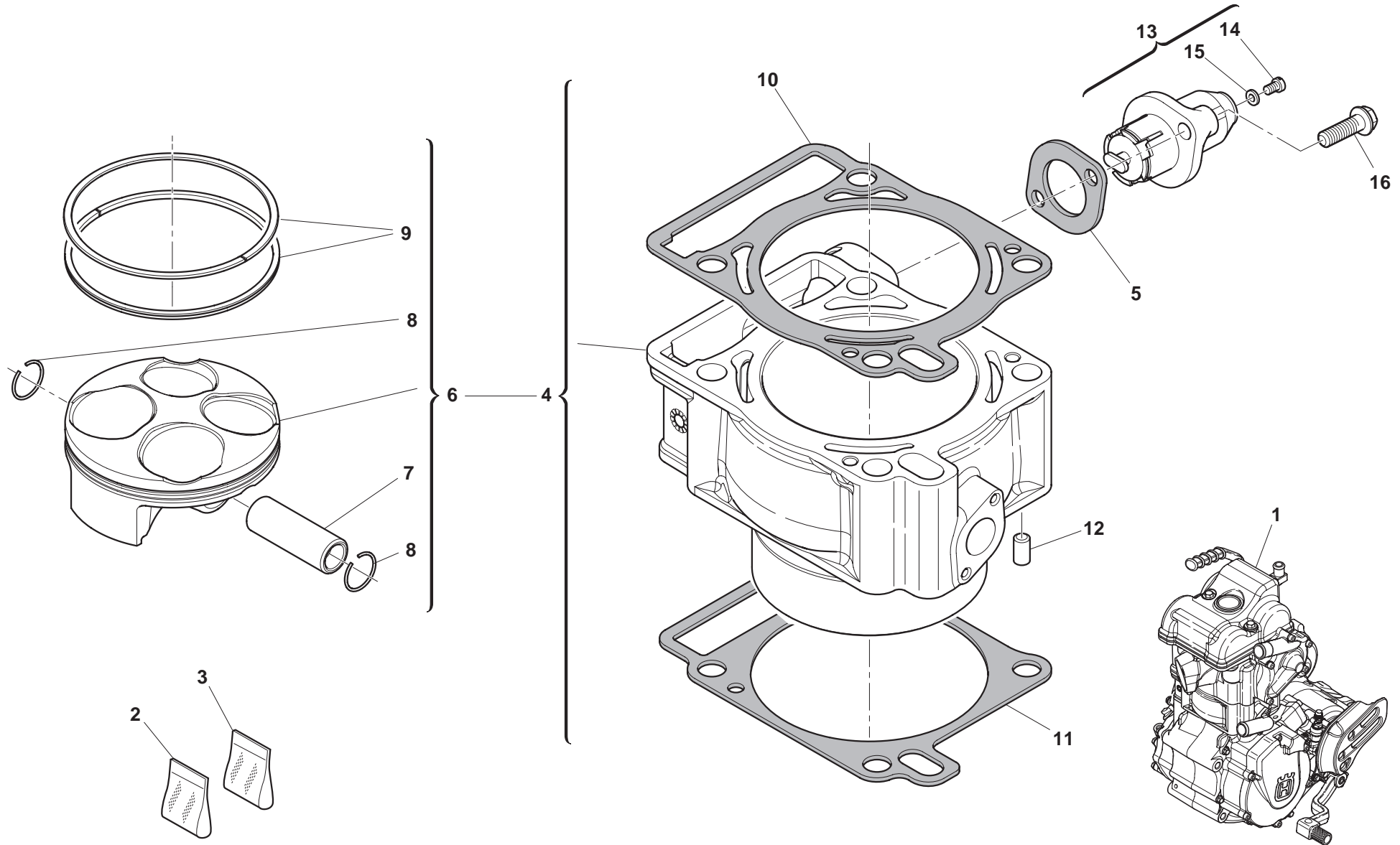



TC 250/2009

**CILINDRO, PISTONE - CYLINDER, PISTON
CYLINDRE, PISTON- ZYLINDER, KOLBEN
CILINDRO, PISTON**

TAVOLA
DRAWING
TABLE
BLD
TABLA

2

Note Notes Marke Notas	Pos. No. N. Index Pos.	N. Cod. CodeNo. Nr. Code Code Nr N. Cod.	Q.tà Qty Q.te M.ge C.ad	DENOMINAZIONE	NAME	DESIGNATION	BESHREIBUNG	DENOMINACION	Validità Validity Validité Gültig Validez
	1	8000 H0002	1	Assieme Motore	Engine assy	Moteur complet	Motor kpl.	Motor completo	
	2	8000 A6344	1	Kit anelli di tenuta motore	Engine seal ring set	Groupe bague moteur	Dichtungringgruppe Motor	Grupo anillos motor	
	3	8000 A6342	1	Guarnizioni motore	Gasket set	Groupe garnitures	Dichtungssatz	Grupo juntas motor	
	4	8000 A6567	1	Assieme cilindro completo di pistone	Cylinder and piston set	Cylindre, piston complet	Zylinder, Kolben komplett	Cilindro, Pistón completo	
	5	8000 A6954	1	Guarnizione	Gasket	Garniture	Dichtung	Junta	
	6	8000 A6569	1	Assieme pistone completo	Piston set	Piston complet	Kolben, kompl.	Pistón, completo	
	7	8000 A6571	1	Spinotto	Gudgeon	Axe	Bolzen	Perno	
	8	8000 A6572	2	Anello di fermo	Stop ring	Bague d'arrêt	Haltering	Anillo de retención	
	9	8000 A6573	1	Kit segmenti pistone	Circlip kit	Kit segment	Kolbenring	Kit segmento	
	10	8000 A6576	1	Guarnizione testa (SP= 0,50 mm)	Gasket (SP= 0,50 mm)	Garniture (SP= 0,50 mm)	Dichtung (SP= 0,50 mm)	Junta (SP= 0,50 mm)	
	10	8A00 A6576	1	Guarnizione testa (SP= 0,60 mm)	Gasket (SP= 0,60 mm)	Garniture (SP= 0,60 mm)	Dichtung (SP= 0,60 mm)	Junta (SP= 0,60 mm)	
	10	8B00 A6576	1	Guarnizione testa (SP= 0,70 mm)	Gasket (SP= 0,70 mm)	Garniture (SP= 0,70 mm)	Dichtung (SP= 0,70 mm)	Junta (SP= 0,70 mm)	
	11	8000 A6577	1	Guarnizione cilindro	Gasket	Garniture	Dichtung	Junta	
	12	8000 A6578	2	Spina	Dowel	Plot	Zylinderst	Centraje	
	13	8000 A6950	1	Tendicatena completo	Complete chain tensioner	Tendeur de chaine complet	Kettenspanner komplett	Tensor de cadene completo	
	14	8000 A6357	1	Vite M6-L8	Screws M6-L8	Vis M6-L8	Schraube M6-L8	Tornillo M6-L8	
	15	8000 A6358	1	Rosetta	Washer	Rondelle	Scheibe	Arandela	
	16	8000 62728	2	Vite M6-L20	Screws M6-L20	Vis M6-L20	Schraube M6-L20	Tornillo M6-L20	
	17	8000 A6954	1	Guarnizione	Gasket	Garniture	Dichtung	Junta	

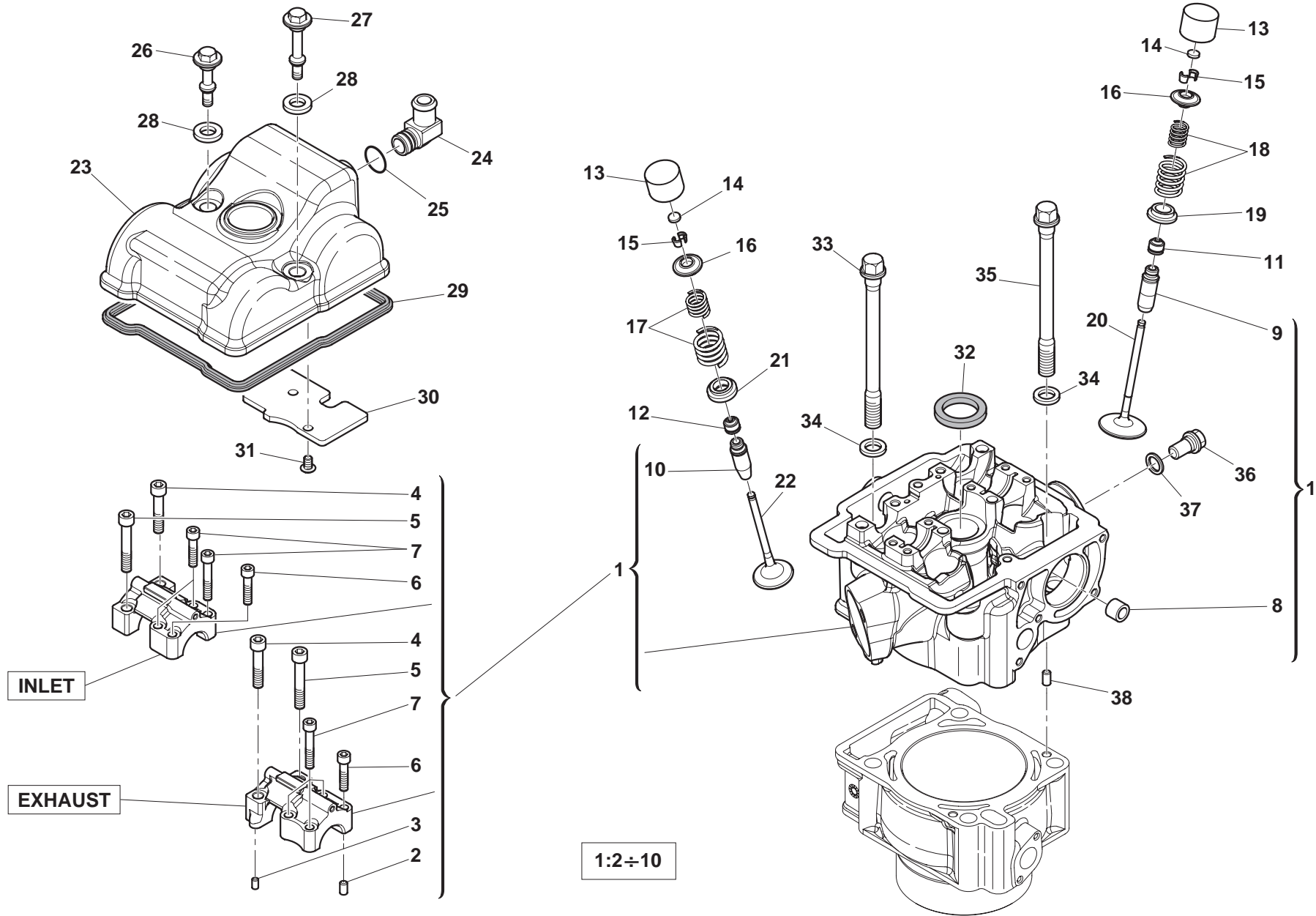

TESTA CILINDRO - CYLINDER HEAD CULASSE - ZYLINDERKOPF CULATA

Note Notes Marke Notas	Pos. No. Index Pos.	N. Cod. Code No. Nr. Code Code Nr N. Cod.	Q.tà Qty Q.te M.ge C.ad	DENOMINAZIONE	NAME	DESIGNATION	BESHREIBUNG	DENOMINACION	Validità Validity Validité Gültig Validez
	1	8000 A6340	1	Testa completa	Cylinder head	Culasse complete	Zylinderkopf Kpl.	Culata completa	
	2	8000 A6350	2	Spina ø8	Dowel ø8	Plot ø8	Zylinderst ø8	Centraje ø8	
	3	8000 A6351	2	Spina ø7	Dowel ø7	Plot ø7	Zylinderst ø7	Centraje ø7	
	4	8A00 A6978	2	Vite M6-L30	Screws M6-L30	Vis M6-L30	Schraube M6-L30	Tornillo M6-L30	
	5	8000A6978	2	Vite M6-L35	Screws M6-L35	Vis M6-L35	Schraube M6-L35	Tornillo M6-L35	
	6	8A00 A7085	2	Vite M5-L30	Screws M5-L30	Vis M5-L30	Schraube M5-L30	Tornillo M5-L30	
	7	8000 A7085	6	Vite M5-L25	Screws M5-L25	Vis M5-L25	Schraube M5-L25	Tornillo M5-L25	
	8	8000 31748	1	Boccola a rullini	Bush	Bague	Bouchse	Buje	
	9	8000 A6352	2	Guida valvola Aspirazione	Intake valve guide	Guide-soupape d'aspiration	Einlaßventilführung	Guia-Válvula de aspiración	
	10	8000 A6353	2	Guida valvola Scarico	Exhaust valve guide	Guide-soupape décharge	Auslaßventilführung	Guia-Válvula de escape	
	11	8000 A6356	2	Anello di tenuta	Seal ring	Bague d'étancheité	Dichtscheibe	Anillo reten	
	12	8000 A6356	2	Anello di tenuta	Seal ring	Bague d'étancheité	Dichtscheibe	Anillo reten	
	13	8000 A6553	4	Bicchierino	Cup	Couvette	Teller	Cubeta	
	14	8000 A6561	4	Pastiglia (1,20 mm)	Pad (1,20 mm)	Plaquette (1,20 mm)	Belag (1,20 mm)	Pastilla (1,20 mm)	
	14	8A00 A6561	4	Pastiglia (1,25 mm)	Pad (1,25 mm)	Plaquette (1,25 mm)	Belag (1,25 mm)	Pastilla (1,25 mm)	
	14	8B00 A6561	4	Pastiglia (1,30 mm)	Pad (1,30 mm)	Plaquette (1,30 mm)	Belag (1,30 mm)	Pastilla (1,30 mm)	
	14	8C00 A6561	4	Pastiglia (1,35 mm)	Pad (1,35 mm)	Plaquette (1,35 mm)	Belag (1,35 mm)	Pastilla (1,35 mm)	
	14	8D00 A6561	4	Pastiglia (1,40 mm)	Pad (1,40 mm)	Plaquette (1,40 mm)	Belag (1,40 mm)	Pastilla (1,40 mm)	
	14	8E00 A6561	4	Pastiglia (1,45 mm)	Pad (1,45 mm)	Plaquette (1,45 mm)	Belag (1,45 mm)	Pastilla (1,45 mm)	
	14	8F00 A6561	4	Pastiglia (1,50 mm)	Pad (1,50 mm)	Plaquette (1,50 mm)	Belag (1,50 mm)	Pastilla (1,50 mm)	
	14	8G00 A6561	4	Pastiglia (1,55 mm)	Pad (1,55 mm)	Plaquette (1,55 mm)	Belag (1,55 mm)	Pastilla (1,55 mm)	
	14	8000 A2141	4	Pastiglia (1,60 mm)	Pad (1,60 mm)	Plaquette (1,60 mm)	Belag (1,60 mm)	Pastilla (1,60 mm)	
	14	8A00 A2141	4	Pastiglia (1,65 mm)	Pad (1,65 mm)	Plaquette (1,65 mm)	Belag (1,65 mm)	Pastilla (1,65 mm)	
	14	8B00 A2141	4	Pastiglia (1,70 mm)	Pad (1,70 mm)	Plaquette (1,70 mm)	Belag (1,70 mm)	Pastilla (1,70 mm)	
	14	8C00 A2141	4	Pastiglia (1,75 mm)	Pad (1,75 mm)	Plaquette (1,75 mm)	Belag (1,75 mm)	Pastilla (1,75 mm)	
	14	8D00 A2141	4	Pastiglia (1,80 mm)	Pad (1,80 mm)	Plaquette (1,80 mm)	Belag (1,80 mm)	Pastilla (1,80 mm)	
	14	8E00 A2141	4	Pastiglia (1,85 mm)	Pad (1,85 mm)	Plaquette (1,85 mm)	Belag (1,85 mm)	Pastilla (1,85 mm)	
	14	8F00 A2141	4	Pastiglia (1,90 mm)	Pad (1,90 mm)	Plaquette (1,90 mm)	Belag (1,90 mm)	Pastilla (1,90 mm)	
	14	8G00 A2141	4	Pastiglia (1,95 mm)	Pad (1,95 mm)	Plaquette (1,95 mm)	Belag (1,95 mm)	Pastilla (1,95 mm)	
	14	8H00 A2141	4	Pastiglia (2,00 mm)	Pad (2,00 mm)	Plaquette (2,00 mm)	Belag (2,00 mm)	Pastilla (2,00 mm)	
	14	8J00 A2141	4	Pastiglia (2,05 mm)	Pad (2,05 mm)	Plaquette (2,05 mm)	Belag (2,05 mm)	Pastilla (2,05 mm)	
	15	8000 92433	8	Semicono	Half cone	Demi-cône	Halb Kegel	Semi-cono	
	16	8000 A6364	4	Scodellino	Cup	Couvette	Teller	Cubeta	

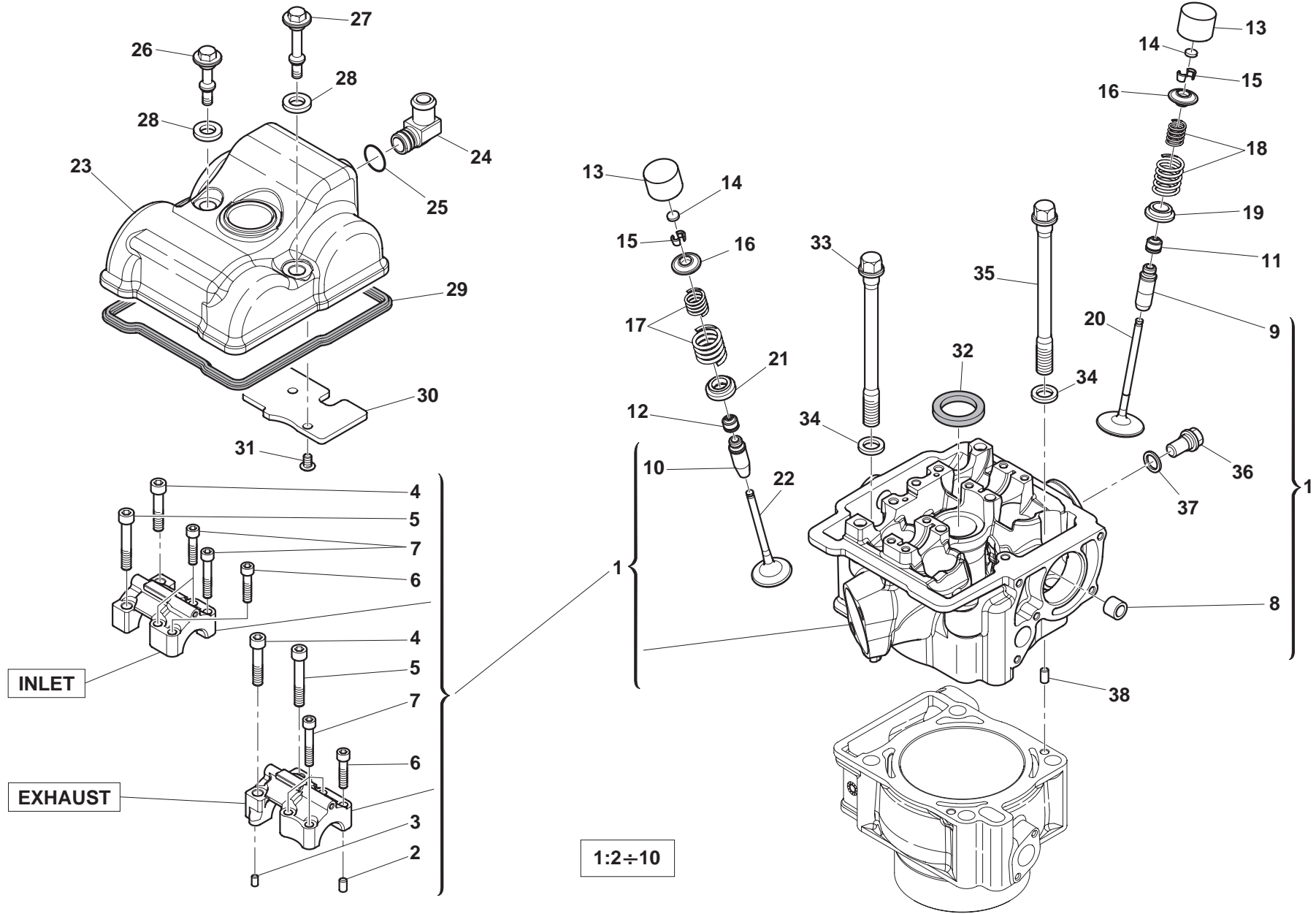

**TESTA CILINDRO - CYLINDER HEAD
CULASSE - ZYLINDERKOPF
CULATA**

Note Notes Marke Notas	Pos. No. N. Index Pos.	N. Cod. CodeNo. Nr. Code Code Nr N. Cod.	Q.tà Qty Q.te M.ge C.ad	DENOMINAZIONE	NAME	DESIGNATION	BESHREIBUNG	DENOMINACION	Validità Validity Validité Gültig Validez
	17	8000 A6552	2	Molla scarico	Spring, exhaust	Ressort echappement	Auslass feder	Resorte escape	
	18	8000 A6551	2	Molla aspirazione	Spring, inlet	Ressort admission	Einlass feder	Resorte aspiración	
	19	8000 A6365	2	Piattello aspirazione	Plate, inlet	Disque admission	Platte einlass	Platillo aspiracion	
	20	8000 A6359	2	Valvola aspirazione	Inlet valve	Soupape admission	Einlass-Ventil	Válvula aspiración	
	21	8000 A6366	2	Piattello scarico	Plate, exhaust	Disque echappement	Platte auslass	Platillo escape	
	22	8000 A6362	2	Valvola scarico	Exhaust valve	Soupape d'éch.	Auslaßventil	Válvula de escape	
	23	80B0 A6556	1	Coperchio testa	Cylinder head cover	Couvercle culasse	Zylinderkopfabdeckung	Tapa culata	
	24	8000 A7039	1	Raccordo sfiato	Union	Raccord	Anschluss	Empalme	
	25	8000 01199	1	Anello	O-Ring	Bague OR	O-Ring	Anillo OR	
	26	8000 A6560	1	Vite	Screw	Vis	Schraube	Tornillo	
	27	8000 A7031	1	Vite	Screw	Vis	Schraube	Tornillo	
	28	8000 91588	2	Rosetta di tenuta	Washer	Rondelle	Scheibe	Arandela	
	29	8000 A6562	1	Guarnizione coperchio testa	Cylinder head cover Gasket	Garnitue couvercle culasse	Dichtung	Junta tapa culata	
	30	8000 A6559	1	Piastrina	Plate	Plaque	Platte	Placa	
	31	ZC00 65535	2	Vite M5-L7	Screw M5-L7	Vis M5-L7	Schraube M5-L7	Tornillo M5-L7	
	32	8000 A6563	1	Guarnizione coperchio testa	Cylinder head cover Gasket	Garnitue couvercle culasse	Dichtung	Junta tapa culata	
	33	8A00 A6564	1	Prigioniero M10-L104,5	Stud bolt M10-L104,5	Goujon M10-L104,5	Stiftschraube M10-L104,5	Espárrago M10-L104,5	
	34	8000 23374	4	Rosetta	Washer	Rondelle	Scheibe	Arandela	
	35	8000 A6564	3	Prigioniero M10-L119,5	Stud bolt M10-L119,5	Goujon M10-L119,5	Stiftschraube M10-L119,5	Espárrago M10-L119,5	
	36	8000 B0385	1	Tappo M10	Plug M10	Bouchon M10	Verschluss M10	Tapón M10	
	37	8000 A0575	1	Rosetta	Washer	Rondelle	Scheibe	Arandela	
	38	8000 A6939	2	Spina	Dowel	Plot	Zylinderst	Centraje	

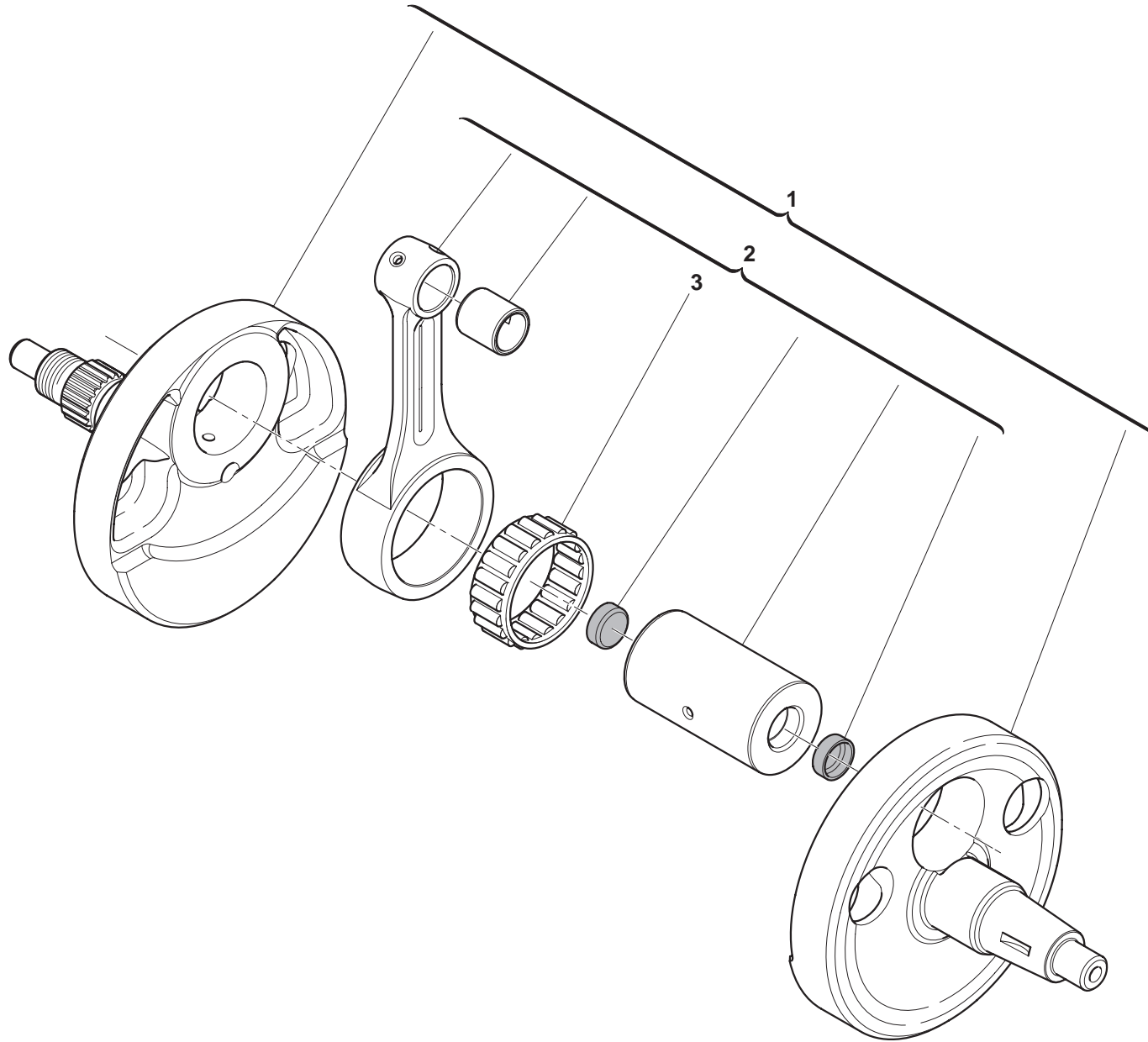

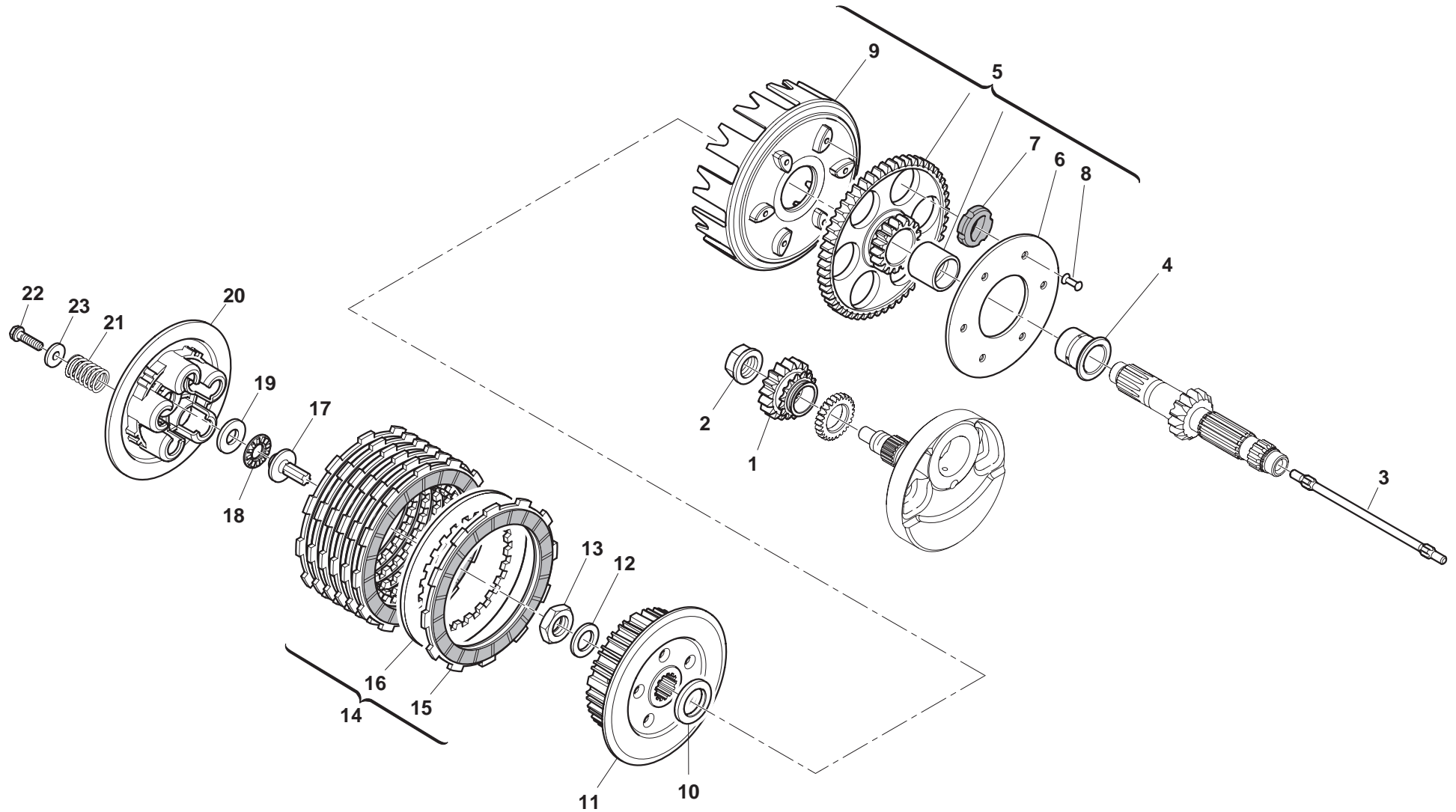



TC 250/2009

TRASMISSIONE PRIMARIA, FRIZIONE - PRIMARY DRIVE, CLUTCH
TRANSMISSION PRIMAIRE, EMBRAYAGE
PRIMÄRÜBERSETZUNG, KUPPLUNG - TRANSMISION PRIMARIA, EMBRAGUE

TAVOLA
DRAWING
TABLE
BLD
TABLA

5

Note Notes Marka Notas	Pos. No. N. Index Pos.	N. Cod. CodeNo. Nr. Code Code Nr N. Cod.	Q.tà Qty Q.te M.ge C.ad	DENOMINAZIONE	NAME	DESIGNATION	BESHREIBUNG	DENOMINACION	Validità Validity Validité Gültig Validez
	1	8000 A6607	1	Ingranaggio conduttore (Z17)	Driving gear (Z17)	Engrange conducteur (Z17)	Antriebszahnrad (Z17)	Engranaje conductor (Z17)	
	2	8000 A6617	1	Dado	Nut	Ecrou	Mutter	Tuerca	
	3	8000 A7045	1	Astina disinnesto frizione	Control rod.	Coulisseau	Steuerstange	Varilla	
	4	8000 A6616	1	Bussola	Bushing	Douille	Bouchse	Manguito	
	5	8000 A6608	1	Ingr. condotto completo (Z54)	Driving gear assy (Z54)	Engrange compl. (Z54)	Zahnrad komplett (Z54)	Engranaje completo (Z54)	
	6	8A00 65844	1	Disco ritegno	Retainer disc	Reténer disque	Klemmplatte	Disco retendor	
	7	8000 31378	6	Anello	O-Ring	Bague	O-Ring	Anillo	
	8	63N016349	6	Rivetto	Rivet	Rivet	Niet	Remache	
	9	8000 A7077	1	Custodia frizione	Clutch case	Sac embrayage	Kupplungskorb kpl.	Caja embrague	
	10	8000 A7034	1	Rosetta	Washer	Rondelle	Scheibe	Arandela	
	11	8000 A7033	1	Mozzo portadischi	Hub disc carrier	Moyeuporte disque	Nabe	Cubo portadisco	
	12	8000 29089	1	Rosetta	Washer	Rondelle	Scheibe	Arandela	
	13	8A00 31386	1	Dado M16	Nut M16	Ecrou M16	Mutter M16	Tuerca M16	
	14	8000 A7037	1	Ass. gruppo dischi frizione	Clutch group assy	Gr. embrayage compl.	Kupplungsgruppe	Gr. embrague compl.	
	15	8000 A7038	7	Disco frizione guarnito	Clutch disc	Disque embrayage	Kupplungsscheibe	Disco de embragu	
	16	8000 88818	6	Disco condotto liscio	Driven disc	Disque conduit	Scheibe	Disco conducido	
	17	8000 A7046	1	Perno comando frizione	Clutch control pin	Axe commande embrayage	Kupplungssteuerstift	Perno mando embrague	
	18	8000 70550	1	Gabbia assiale a rulli	Needle bearing cage	Cage a aiguilles	Nadelkfig	Sombrerete de cojinete	
	19	8000 70551	1	Ralla	Washer	Rondelle	Unterlegscheibe	Arandela	
	20	8000 70467	1	Piatto spingidisco	Push disc plate	Pousser disque plaque	Stoben scheibe	Empujar disco	
	21	8000 71230	5	Molla per frizione	Clutch spring	Embrayage ressort	Kupplung feder	Embrague resorte	
	22	8000 62728	5	Vite M6-L20	Screw M6-L20	Vis M6-L20	Schraube M6-L20	Tornillo M6-L20	
	23	8000 48814	5	Rosetta	Washer	Rondelle	Scheibe	Arandela	

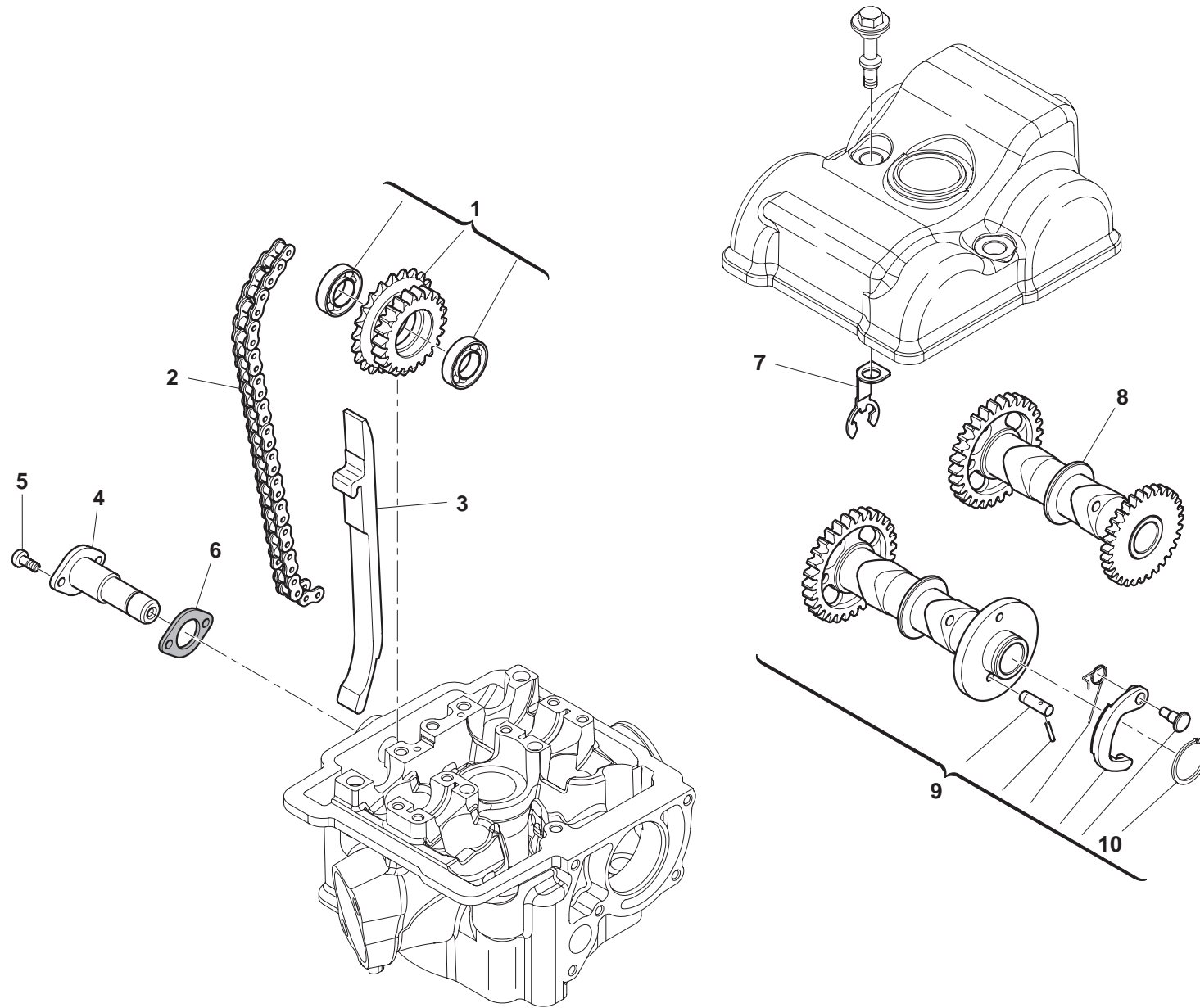

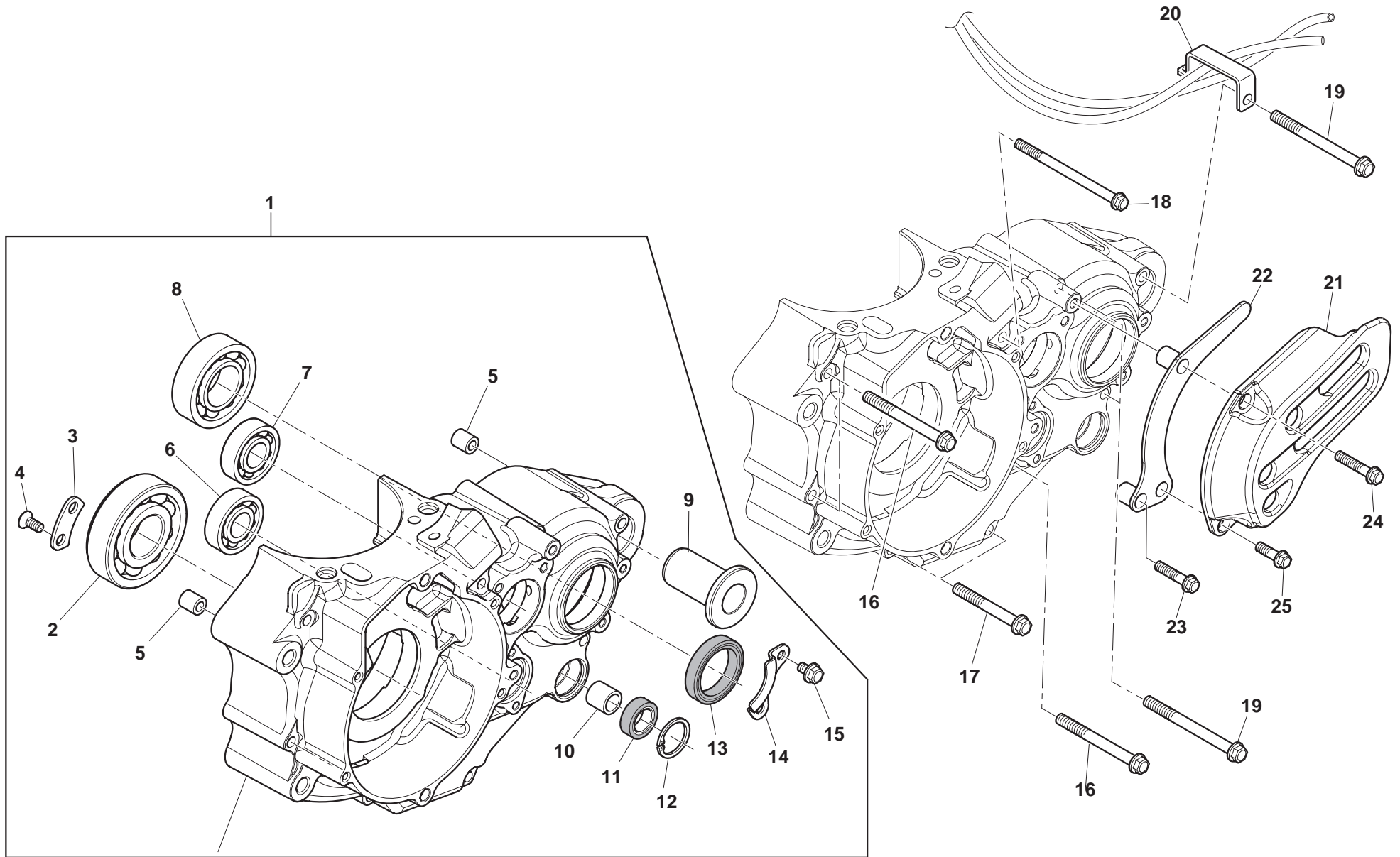



TC 250/2009

SEMICARTER SINISTRO - L.H. HALF CRANKCASE CARTER G. - GEHAUSEDECKEL L. BANCADA IZQ.

TAVOLA
DRAWING
TABLE
BLD
TABLA

7

Note Notes Notas	Pos. No. Index Pos.	N. Cod. Code No. Nr. Code Code Nr N. Cod.	Q.tà Qty Q.te M.ge C.ad	DENOMINAZIONE	NAME	DESIGNATION	BESHREIBUNG	DENOMINACION	Validità Validity Validité Gültig Validez
	1	8000 A6968	1	Carter motore accoppiati compl.	Crankcase assy	Carter compl.	Kurberlgehausa komplett	Carter motor completi	
	2	8000 A6970	1	Cuscinetto D25-D62-SP17	Bearing D25-D62-SP17	Roulement D25-D62-SP17	Kugellager D25-D62-SP17	Cojinete D25-D62-SP17	
	3	8000 A6971	2	Piastrina ritegno cuscinetto	Plate cover	Plaquette	Plättchen	Plaquita	
	4	Z000 65328	4	Vite M5-L12	Screw M5-L12	Vis M5-L12	Schraube M5-L12	Tornillo M5-L12	
	5	8000 A6967	2	Bussola	Bushing	Douille	Buchse	Manguito	
	6	8000 A6975	1	Cuscinetto D30-D42-SP7	Bearing D30-D42-SP7	Roulement D30-D42-SP7	Kugellager D30-D42-SP7	Cojinete D30-D42-SP7	
	7	8000 A6972	1	Cuscinetto D17-D35-SP10	Bearing D17-D35-SP10	Roulement D17-D35-SP10	Kugellager D17-D35-SP10	Cojinete D17-D35-SP10	
	8	8000 A6973	1	Cuscinetto D22-D50-SP14	Bearing D22-D50-SP14	Coussinet D22-D50-SP14	Kugellager D22-D50-SP14	Cojinete D22-D50-SP14	
	9	8000 73500	1	Bussola	Bushing	Douille	Buchse	Manguito	
	10	8A00 65847	1	Boccola	Bush	Bague	Bouchse	Buje	
	11	8000 28855	1	Anello	Ring	Anneau	Ring	Anillo	
	12	66N0 21258	1	Anello elastico	Snap ring	Circlip	Sicherungsring	Circlip interior	
	13	8000 A6981	1	Anello di tenuta	Seal ring	Bague de retenue	Dichtring	Anillo de retención	
	14	8000 A6982	1	Piastrina ritegno paraolio	Plate cover	Plaquette	Plättchen	Plaquita	
	15	ZD00 67997	2	Vite M5-L8	Screw M5-L8	Vis M5-L8	Schraube M5-L8	Tornillo M5-L8	
	16	ZD00 67545	3	Vite M6-L60	Screw M6-L60	Vis M6-L60	Schraube M6-L60	Tornillo M6-L60	
	17	ZB00 67545	2	Vite M6-L55	Screw M6-L55	Vis M6-L55	Schraube M6-L55	Tornillo M6-L55	
	18	ZU00 67545	1	Vite M6-L90	Screw M6-L90	Vis M6-L90	Schraube M6-L90	Tornillo M6-L90	
	19	ZG00 67545	3	Vite M6-L70	Screw M6-L70	Vis M6-L70	Schraube M6-L70	Tornillo M6-L70	
	20	8000H0643	1	Piastra fiss. tubi sfiato carburatore	Pipe retain plate	Plaquette	Plättchen	Plaquita	
	21	80A0 66973	1	Coperchio pignone catena	Cover	Couvercle	Deckel	Tapa	
	22	8000 H1016	1	Piastra guidacatena	Plate chain	Plaquette chaine	Plättchen	Plaquita cadene	
	23	8PA0 67545	1	Vite M6-L22	Screw M6-L22	Vis M6-L22	Schraube M6-L22	Tornillo M6-L22	
	24	8000 62730	1	Vite M6-L30	Screw M6-L30	Vis M6-L30	Schraube M6-L30	Tornillo M6-L30	
	25	8000 62725	1	Vite M6-L10	Screw M6-L10	Vis M6-L10	Schraube M6-L10	Tornillo M6-L10	

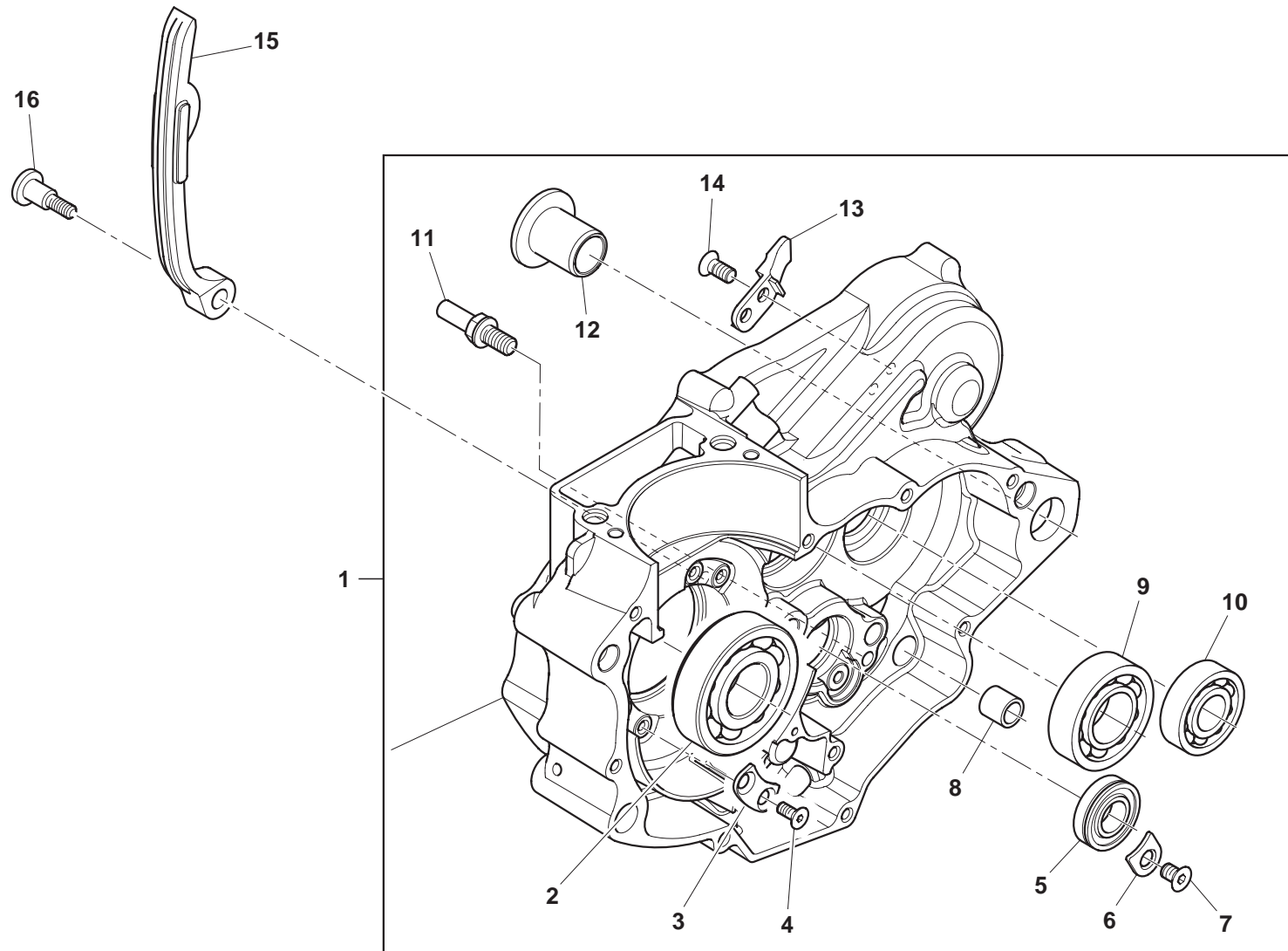



TC 250/2009

SEMICARTER DESTRO - R.H. HALF CRANKCASE CARTER D. - GEHAUSEDECKEL R. BANCADA DER.

TAVOLA
DRAWING
TABLE
BLD
TABLA

8

Note Notes Marke Notas	Pos. No. N. Index Pos.	N. Cod. CodeNo. Nr. Code Code Nr N. Cod.	Q.tà Qty Q.te M.ge C.ad	DENOMINAZIONE	NAME	DESIGNATION	BESHREIBUNG	DENOMINACION	Validità Validity Validité Gültig Validez
	1	8000 A6968	1	Carter motore accoppiati compl.	Crankcase assy	Carter compl.	Kurberlgehäuse kpl.	Carter motor completi	
	2	8000 A6970	1	Cuscinetto D25-D62-SP17	Bearing D25-D62-SP17	Roulement D25-D62-SP17	Kugellager D25-D62-SP17	Cojinete D25-D62-SP17	
	3	8000 A6971	2	Piastrina ritegno cuscinetto	Plate cover	Plaquette	Plättchen	Plaquita	
	4	Z000 65328	4	Vite M5-L12	Screw M5-L12	Vis M5-L12	SchraubeM5-L12	Tornillo M5-L12	
	5	8000 A6988	1	Cuscinetto D15-D32-SP9	Bearing D15-D32-SP9	Roulement D15-D32-SP9	Kugellager D15-D32-SP9	Cojinete D15-D32-SP9	
	6	8000 A6955	1	Piastrina ritegno cuscinetto	Plate cover	Plaquette	Plättchen	Plaquita	
	7	ZA00 28327	1	Vite M6-L10	Screw M6-L10	Vis M6-L10	SchraubeM6-L10	Tornillo M6-L10	
	8	8A00 65847	1	Boccola	Bush	Bague	Buchse	Buje	
	9	8000 A6973	1	Cuscinetto D22-D50-SP14	Bearing D22-D50-SP14	Coussinet D22-D50-SP14	Lager D22-D50-SP14	Cojinete D22-D50-SP14	
	10	8000 10452	1	Cuscinetto D17-D40-SP12	Bearing D17-D40-SP12	Roulement D17-D40-SP12	Lager D17-D40-SP12	Cojinete D17-D40-SP12	
	11	8000 A6989	1	Perno	Pin	Pilot	Bolzen	Perno	
	12	8000 73500	1	Bussola	Bushing	Douille	Buchse	Manguito	
	13	8000 A7088	1	Piastrina disinnesto avviamento	Disconnect plate	Plaquette débrancher	Ausschalten	Placa desconectar	
	14	Z000 28327	2	Vite M6-L14	Screw M6-L14	Vis M6-L14	Schraube M6-L14	Tornillo M6-L14	
	15	8000 A6958	1	Pattino mobile	Pad sliding	Patin	Gleitblock	Patin	
	16	8000 A6960	1	Vite	Screw	Vis	Schraube	Tornillo	

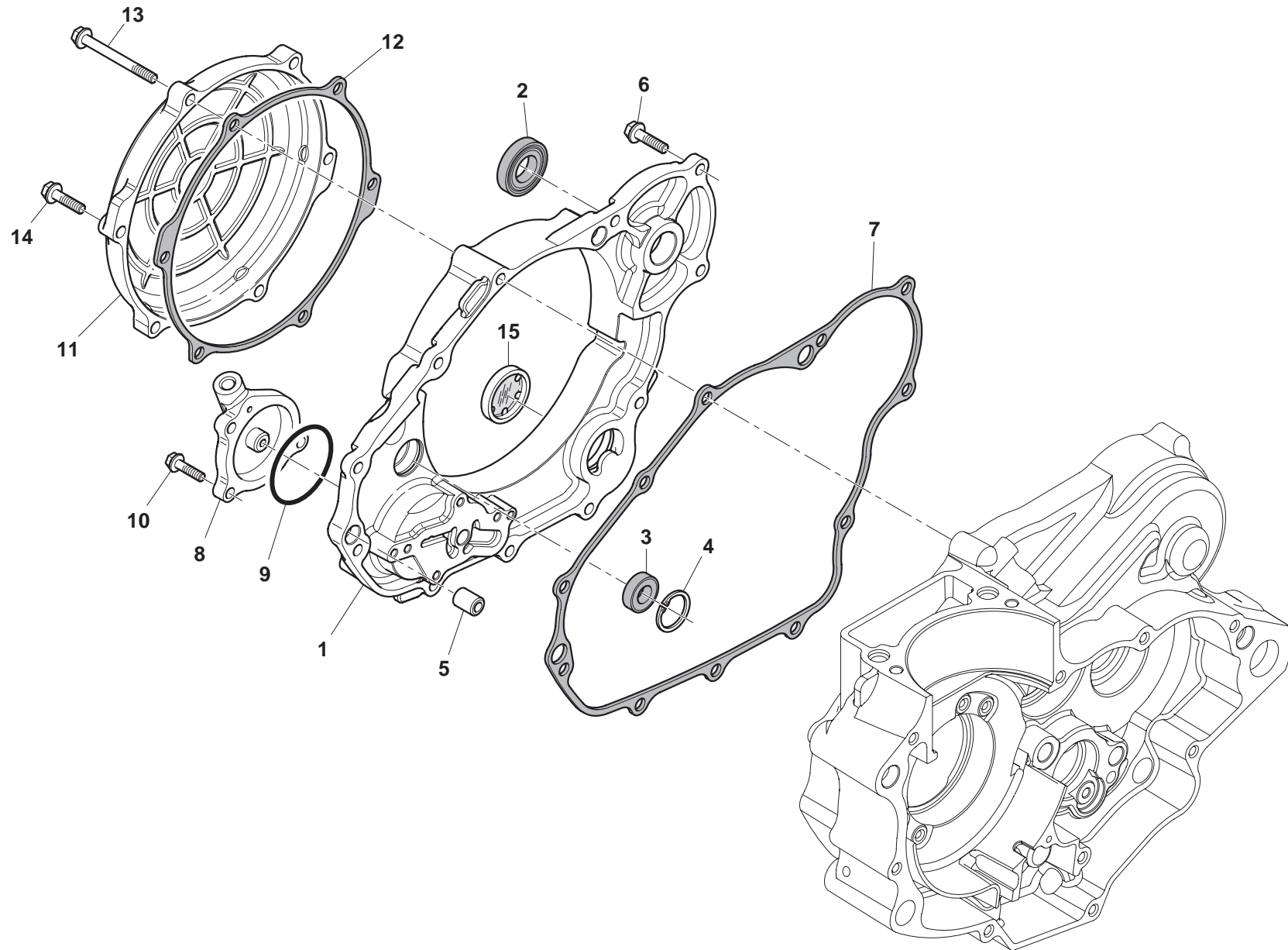

COPERCHI SEMICARTER DESTRO - R.H. HALF CRANKCASE COVERS
COUVERCLES CARTER D. - GEHAUSEDECKEL R.
TAPAS BANCADA DER.

Note Notes Mark Notas	Pos. No. N. Index Pos.	N. Cod. Code No. Nr. Code Code Nr N. Cod.	Q.tà Qty Q.te M.ge C.ad	DENOMINAZIONE	NAME	DESIGNATION	BESHREIBUNG	DENOMINACION	Validità Validity Validité Gültig Validez
	1	80A0 A6994	1	Coperchio carter verniciato	Carter cover	Carter couvercle	Deckelgehäuse	Tapa del carte	
	2	8000 A6976	1	Anello di tenuta D30-D18-SP6	Seal ring D30-D18-SP6	Bague de retenue D30-D18-SP6	Dichtring D30-D18-SP6	Anillo de retención D30-D18-SP6	
	3	8000 A6996	1	Anello di tenuta D20-D10-SP6	Seal ring D20-D10-SP6	Bague de retenue D20-D10-SP6	Dichtring D20-D10-SP6	Anillo de retención D20-D10-SP6	
	4	66N0 21257	1	Anello ritegno spinotto	Circlip	Circlip	Haltering	Retenedor	
	5	8000 A6966	2	Bussola D10-SP12 centraggio	Bushing D10-SP12	Douille D10-SP12	Buchse D10-SP12	Manguito D10-SP12	
	6	8000 62728	10	Vite M6-L20	Screw M6-L20	Vis M6-L20	Schraube M6-L20	Tornillo M6-L20	
	7	8000 A6997	1	Guarnizione coperchio destra	Gasket cover right	Joint couvercle droite	Dichtscheibe springtau	Cuberta junta derecha	
	8	80A0 A7000	1	Coperchio filtro olio	Oil filter cover	Couvercle filtre huile	Deckel	Tapa	
	9	8000 A7001	1	Anello	Ring	Bague	Ring	Anillo	
	10	8A00 66525	3	Vite M5-L16	Screw M5-L16	Vis M5-L16	Schraube M5-L16	Tornillo M5-L16	
	11	80A0 A6998	1	Coperchio frizione	Clutch cover	Couvercle d'embarayage	Kupplungsdeckel	Tapa embrague	
	12	8000 A6999	1	Guarnizione	Gasket	Garnitue	Dichtung	Junta	
	13	8000 67545	1	Vite M6-L50	Screw M6-L50	Vis M6-L50	Schraube M6-L50	Tornillo M6-L50	
	14	8PA0 67545	5	Vite M6-L22	Screw M6-L22	Vis M6-L22	Schraube M6-L22	Tornillo M6-L22	
	15	8000 A6995	1	Oblò	Port-hole	Hublot	Bullaage	Portilla	

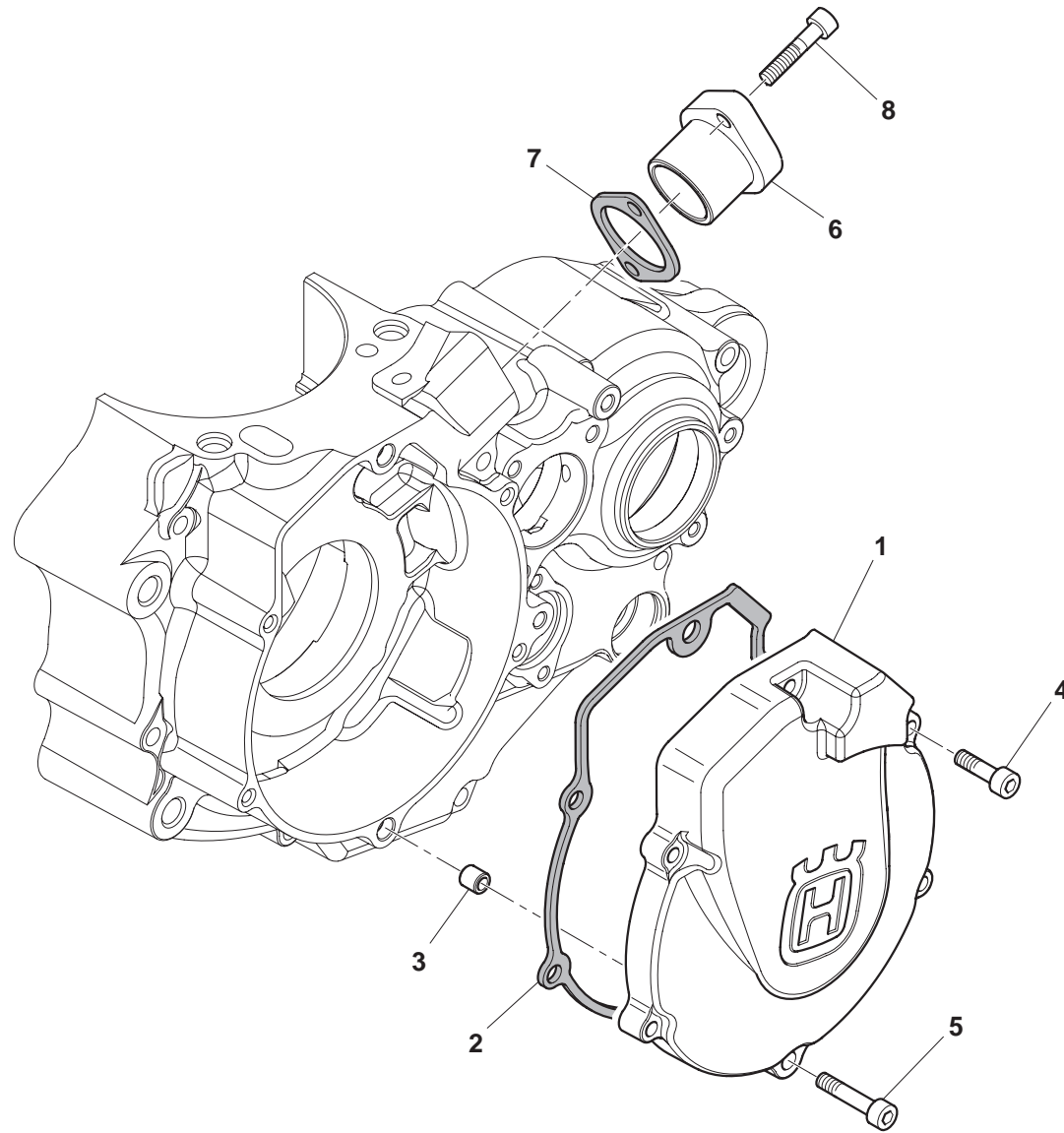

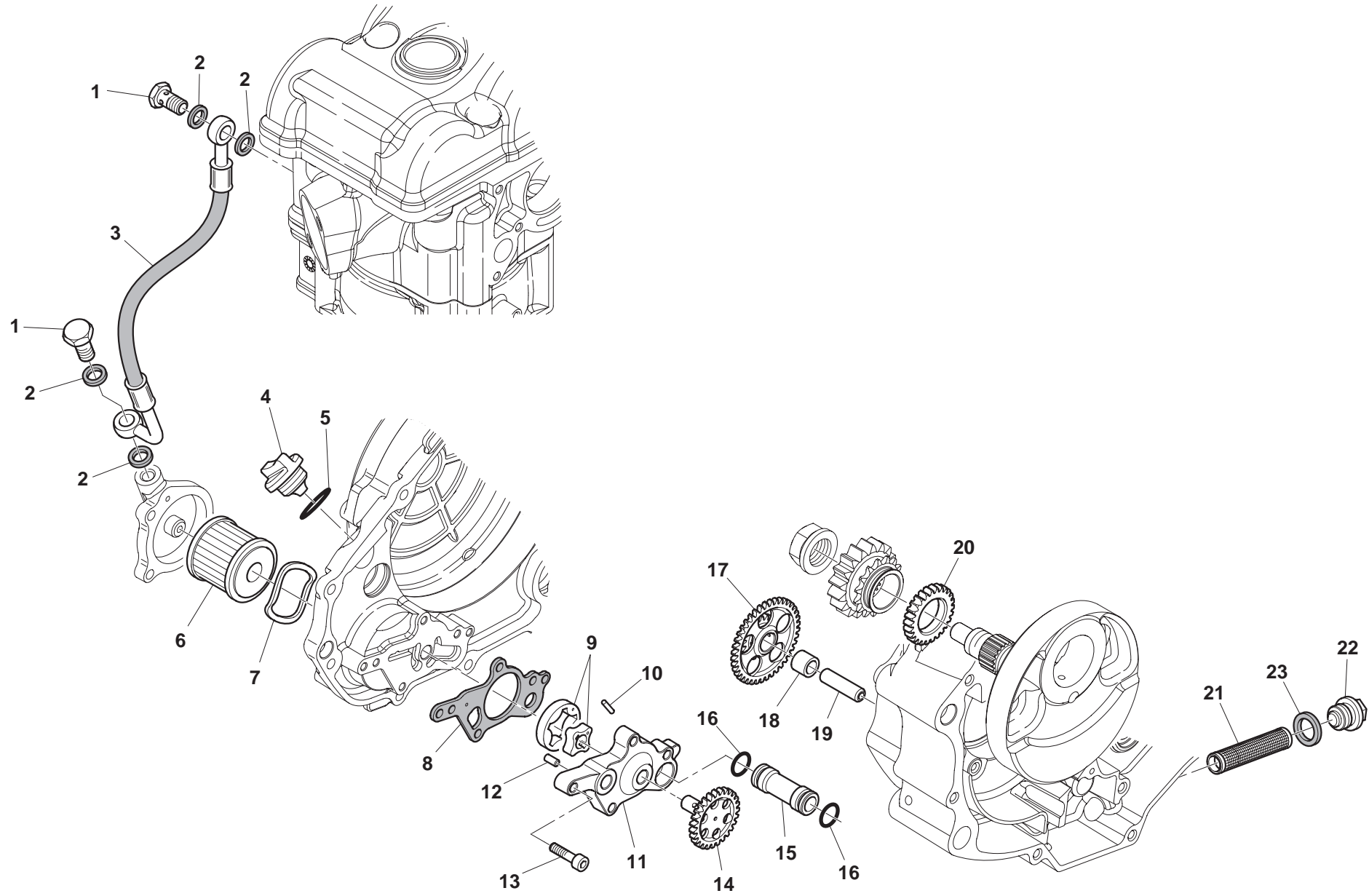

Note Notes Notas	Pos. No. Index Pos.	N. Cod. CodeNo. Nr. Code Code Nr N. Cod.	Q.tà Qty Q.te M.ge C.ad	DENOMINAZIONE	NAME	DESIGNATION	BESHREIBUNG	DENOMINACION	Validità Validity Validité Gültig Validez
	1	8000 A7023	2	Vite	Screw	Vis	Schraube	Tornillo	
	2	8000 40924	4	Rosetta di tenuta	Washer	Rondelle	Scheibe	Arandela	
	3	8000 A7022	1	Tubo mandata olio	Oil pipe	Tuyauterie d'huile	Oelrohr	Tubo aceite	
	4	8000 36786	1	Tappo carico olio	Oil filling cap	Bouchon rempl. huile	Öleinfüllstöpsel	Tapón intruducción aceite	
	5	8000 29171	1	OR	OR	OR	OR	OR	
	6	8000 A7019	1	Filtro olio a cartuccia	Oil filter element	Element filtrant huile	Filtereinsatz	Elemento de filtrado aceite	
	7	8000 A7011	1	Rosetta	Washer	Rondelle	Scheibe	Arandela	
	8	8000 A7061	1	Guarnizione	Gasket	Garnitue	Dichtung	Junta	
	9	8000 A7007	1	Rotori olio	Rotor assy.	Rotor compl.	Rotor kpl.	Rotor compl.	
	10	6BN0 A7474	1	Rullino	Roller	Aiguille	Rolle	Rodillo	
	11	8000 A7009	1	Ass. corpo pompa	Body Pump	Corps de pompe	Pumpengehause	Cuerpo de bomba	
	12	8000 A7012	2	Spina	Dowel	Plot	Zylinderst	Centraje	
	13	60N4 02487	4	Vite M5-L20	Screw M5-L20	Vis M5-L20	Schraube M5-L20	Tornillo M5-L20	
	14	8000 A7006	1	Albero pompa con ingranaggio	Pump shaft	Arbre pompe	Pumpenwelle	Eje bomba	
	15	8000 A7017	1	Tubo olio	Oil pipe	Tuyauterie d'huile	Oelrohr	Tubo aceite	
	16	8000 01199	2	OR	OR	OR	OR	OR	
	17	8000 A7014	1	Ingranaggio intermedio	Idler gear	Engrenage secondaire	Zwischenzahnrad	Engranaje secundario	
	18	8000 31748	1	Boccola rullini	Bush	Bague	Bouchse	Buje	
	19	8000 A7016	1	Albero	Shaft	Arbre	Welle	Arbol	
	20	8000 A7013	1	Ingranaggio conduttore	Driving gear	Engrenage conducteur	Antriebszahnrad	Engranaje conductor	
	21	8000 A7020	1	Filtro a rete	Filter	Filtre	Filter	Filtro	
	22	8000 A7021	1	Tappo scarico olio	Oil drain plug	Bouchon vidange huile	Stöpsel f. ölablass	Tapón purga aceite	
	23	8000 47763	1	Rosetta	Washer	Rondelle	Scheibe	Arandela	

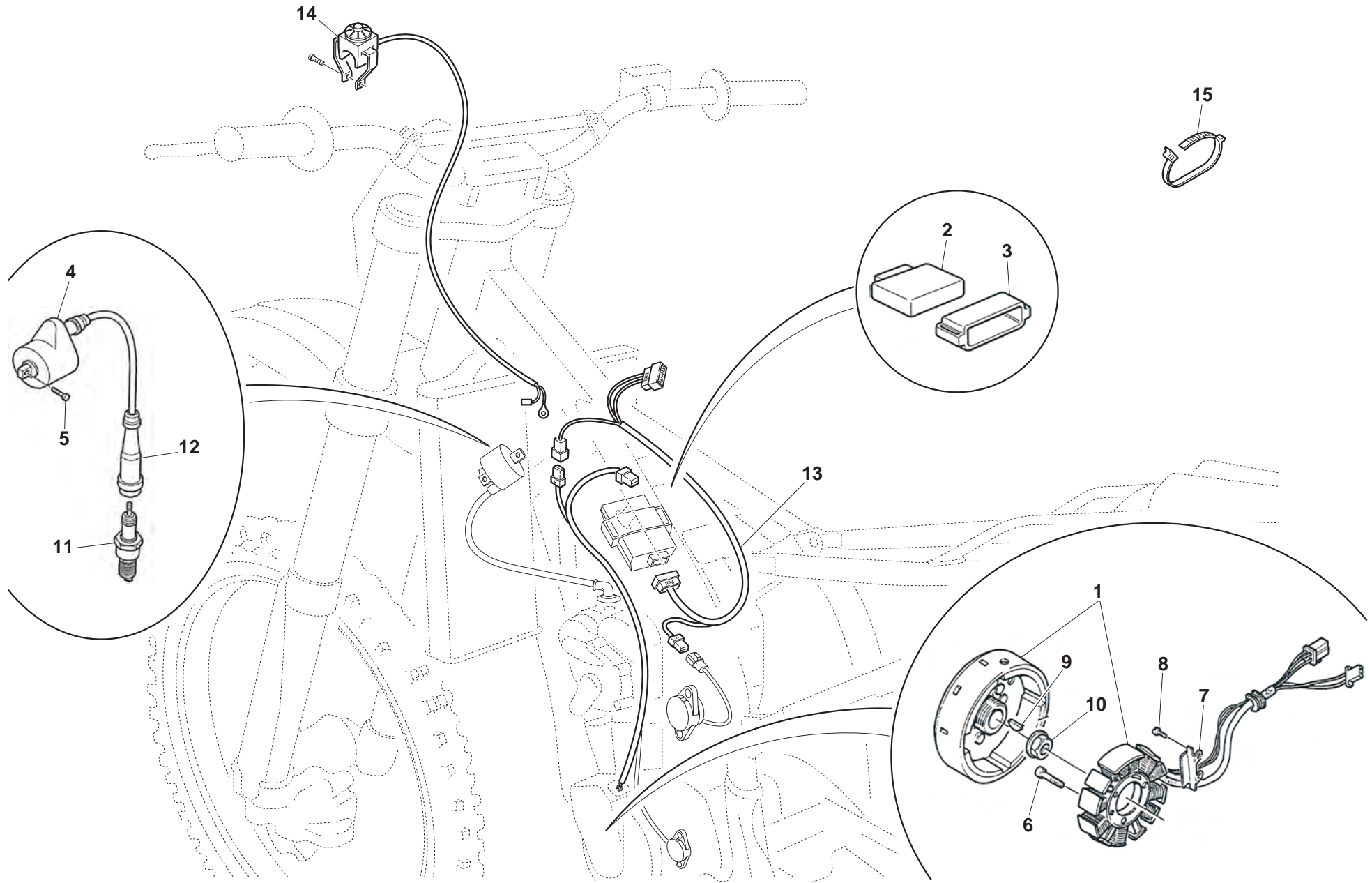

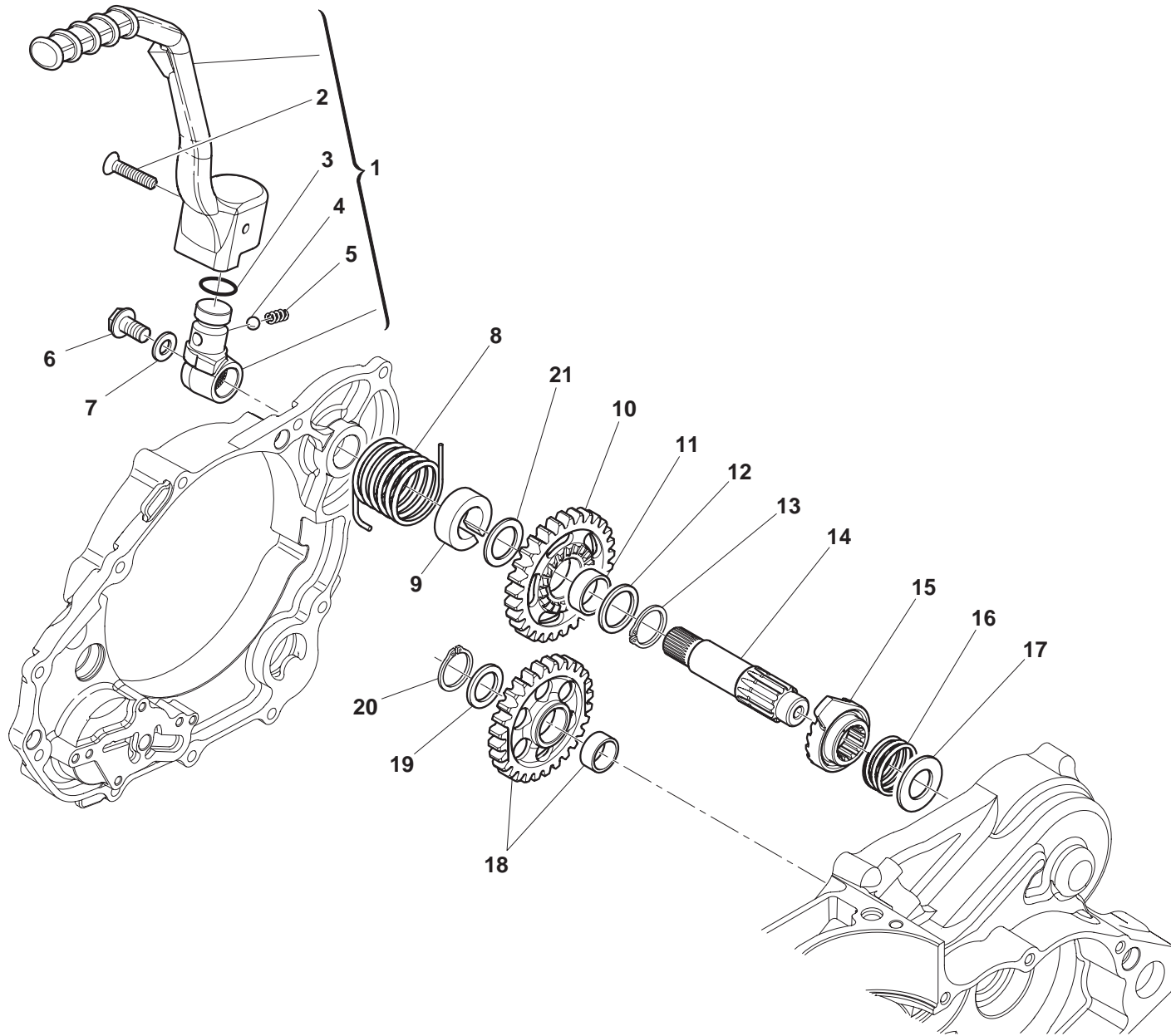

AVVIAMENTO - STARTING DEMARRAGE - ANLASSER ARRANQUE

Note Notes Notes Marke Notas	Pos. No. N. Index Pos.	N. Cod. CodeNo. Nr. Code Code Nr N. Cod.	Q.tà Qty Q.te M.ge C.ad	DENOMINAZIONE	NAME	DESIGNATION	BESHREIBUNG	DENOMINACION	Validità Validity Validité Gültig Validez
	1	8000 A7092	1	Ass. leva avviamento	Pedal assy	Pedale compl.	Pedal kpl.	Pedal compl.	
	2	8000 38287	1	Vite	Screw	Vis	Schraube	Tornillo	
	3	8000 36380	1	OR	OR	OR	OR	OR	
	4	6BNO 21507	1	Sfera 1/4"	Ball 1/4"	Bille 1/4"	Kugel 1/4"	Esfera 1/4"	
	5	1611 08401	1	Molla	Spring	Ressort	Feder	Resorte	
	6	ZB00 69056	1	Vite M8-L19	Screw M8-L19	Vis M8-L19	Schraube M8-L19	Tornillo M8-L19	
	7	Z000 47317	1	Rosetta	Washer	Rondelle	Scheibe	Arandela	
	8	8000 A7083	1	Molla rich. leva avviamento	Spring	Ressort	Feder	Resorte	
	9	8000 A7087	1	Distanziale per molla	Spacer	Entretoise	Distanzstück	Separador	
	10	8000 A7080	1	Ingranaggio avviamento	Start gear	Engrenage demarrage	Zahnrad	Engranaje de arranque	
	11	8000 A7081	1	Boccola	Bush	Bague	Bouchse	Buje	
	12	8000 A7082	1	Rosetta di rasamento	Washer	Rondelle	Scheibe	Arandela	
	13	66NO 21208	1	Anello elastico	Split ring	Anneau ressort	Sprengring	Anillo elástico	
	14	8000 A7078	1	Albero avviamento	Starter crank shaft	Arbre dedémarrage	Kickstarterwellw	Eje arranque	
	15	8000 A7084	1	Cricchetto scorrevole	Sliding gear	Engrenage	Zahnrad	Engranaje	
	16	8000 B5895	1	Molla	Spring	Ressort	Feder	Resorte	
	17	8B00 13332	1	Rosetta	Washer	Rondelle	Scheibe	Arandela	
	18	8000 A6565	1	Ass.ingranaggio di rinvio	Gear idler	Engrenage de renvoi	Vorgelegezahnrad	Engrenaje de reenvio	
	19	8000 A7112	1	Rosetta (SP= 0,5 mm)	Washer (SP= 0,5 mm)	Rondelle (SP= 0,5 mm)	Scheibe (SP= 0,5 mm)	Arandela (SP= 0,5 mm)	
	19	8A00 A7112	1	Rosetta (SP= 0,6 mm)	Washer (SP= 0,6 mm)	Rondelle (SP= 0,6 mm)	Scheibe (SP= 0,6 mm)	Arandela (SP= 0,6 mm)	
	20	66NO 21206	1	Anello elastico	Split ring	Anneau ressort	Sprengring	Anillo elástico	
	21	8C00 48590	1	Rosetta (SP= 0,6 mm)	Washer (SP= 0,6 mm)	Rondelle (SP= 0,6 mm)	Scheibe (SP= 0,6 mm)	Arandela (SP= 0,6 mm)	

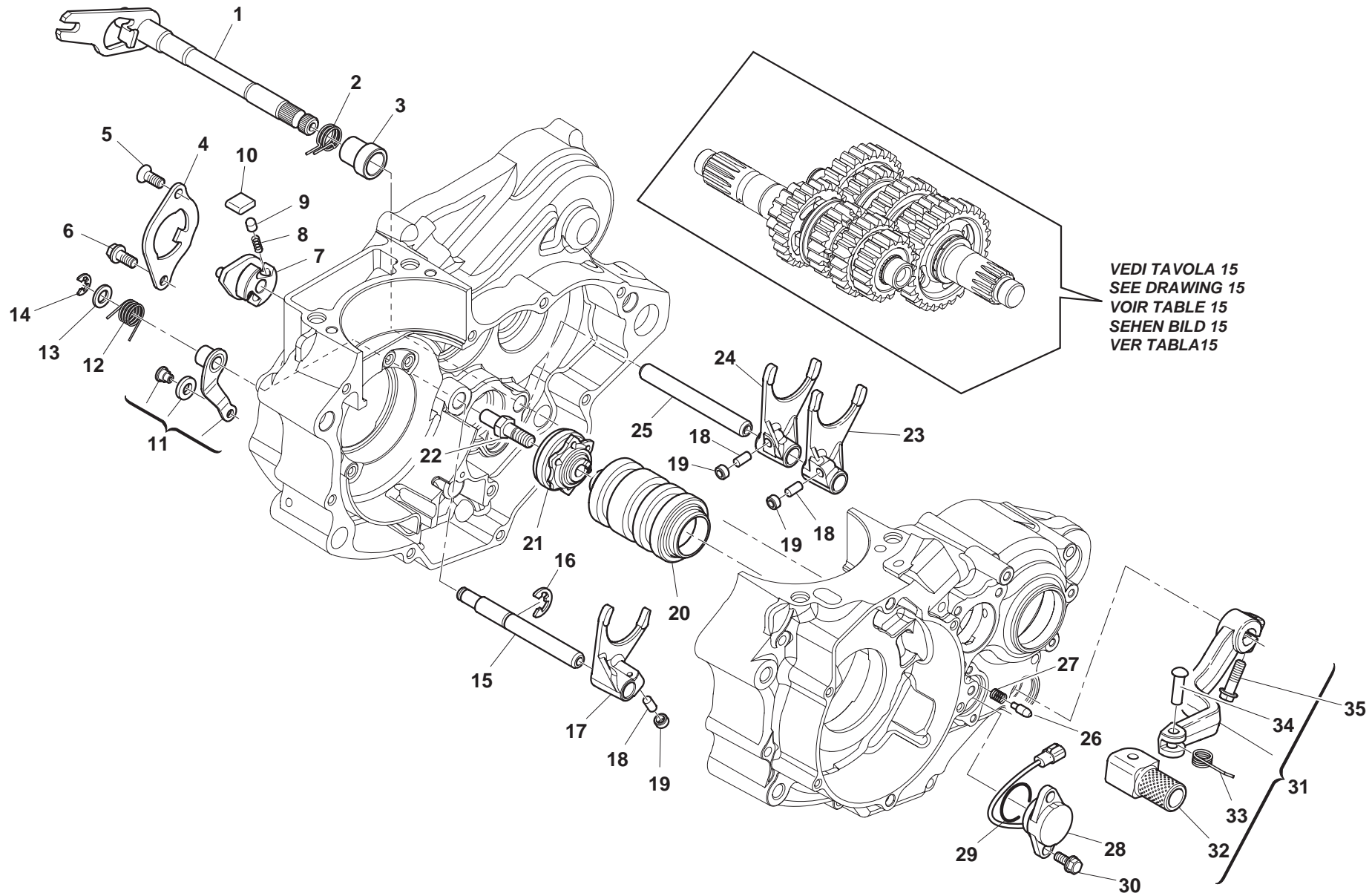

Note Notes Marka Notas	Pos. No. Index Pos.	N. Cod. CodeNo. Nr. Code Code Nr N. Cod.	Q.tà Qty Q.te M.ge C.ad	DENOMINAZIONE	NAME	DESIGNATION	BESHREIBUNG	DENOMINACION	Validità Validity Validité Gültig Validez
	1	8000 A6554	1	Assieme albero selettore	Shaft	Arbre	Welle	Arbol	
	2	8000 A7329	1	Molla richiamo selettore	Spring	Ressort	Feder	Resorte	
	3	8000 A7328	1	Bussola	Bushing	Douille	Buchse	Manguito	
	4	8000 A7318	1	Piastrina di fermo selettore	Stop ring	Bague d'arrêt	Haltering	Anillo de retención	
	5	8000 28327	1	Vite M6-L14	Screw M6-L14	Vis M6-L14	Schraube M6-L14	Tornillo M6-L14	
	6	8000 62726	1	Vite M6-L14	Screw M6-L14	Vis M6-L14	Schraube M6-L14	Tornillo M6-L14	
	7	8000 A7314	1	Rocchetto superiore	Spool	Tiroir	Steuersheiber	Carrette	
	8	8000 71009	2	Molla per puntale	Spring	Ressort	Feder	Resorte	
	9	8000 71008	2	Puntale per saltarello	Push rod	Embout	Stösselschaft	Puntal	
	10	8000 A7315	2	Saltarello per rocchetto	Click	Cliquet	Strumhaken	Salt.	
	11	8000 A7320	1	Saltarello fissamarce	Click	Cliquet	Strumhaken	Salt.	
	12	8A00 A7325	1	Molla per saltarello	Spring	Ressort	Feder	Resorte	
	13	8C00 34292	1	Rosetta	Washer	Rondelle	Scheibe	Arandela	
	14	66N0 21310	1	Anello elastico	Split ring	Anneau ressort	Sprengring	Anillo elástico	
	15	8000 A7312	1	Perno supp. forcella	Pin	Pivot	Bolzen	Perno	
	16	66N0 21312	1	Anello elastico	Split ring	Anneau ressort	Sprengring	Anillo elástico	
	17	8000 A7332	1	Forcella innesto 4°-5°	Yoke 4th-5th	Chape articulata 4ème- 5ème	Gelenkgabel 4°-5°	Yugo 4°-5°	
	18	8000 A7310	3	Perno	Pin	Pivot	Bolzen	Perno	
	19	8000 A7311	3	Rotella	Wheel	Galet	Rädchen	Ruedecilla	
	20	8000 A7331	1	Albero comando forcelle	Shaft	Arbre	Welle	Arbol	
	21	8000 A7305	1	Tamburo selettore marce	Drum	Tambour	Schraube	Tornillo	
	22	8000 A7306	1	Vite fiss.tamburo selettore	Screw	Vis	Schraube	Tornillo	
	23	8000 A7333	1	Forcella innesto 2°	Yoke 2nd	Chape articulata 2ème	Gelenkgabel 2°	Yugo 2°	
	24	8000 A7334	1	Forcella innesto 1°- 3°	Yoke 1st - 3rd	Chape articulata 1ème - 3ème	Gelenkgabel 1°- 3°	Yugo 1°- 3°	
	25	8000 A7313	1	Perno supp. forcella	Pin	Pivot	Bolzen	Perno	
	26	8000 42676	1	Puntale per segnalatore marce	Push rod	Embout	Stösselschaft	Puntal	
	27	8000 42677	1	Molla per puntale	Spring	Ressort	Feder	Resorte	
	28	8000 A4511	1	Segnalatore marce	Idle trasponder assy	Signaleur point mort compl.	Leerlauflicht kpl.	Señalador compl.	
	29	8A00 42700	1	OR	OR	OR	OR	OR	
	30	8000 66525	2	Vite M5-L12	Screw M5-L12	Vis M5-L12	Schraube M5-L12	Tornillo M5-L12	
	31	8000 A3488	1	Ass.leva comando cambio	Gearchange lever	Levier comm.vitesse	Schalthebe	Palanca del cambio	
	32	8A00 A3485	1	Pedalino per leva comando cambio	Gearchange level pedal	Pedale	Pedal	Pedal	
	33	8000 70216	1	Molla per pedalino comando cambio	Spring	Ressort	Feder	Resorte	

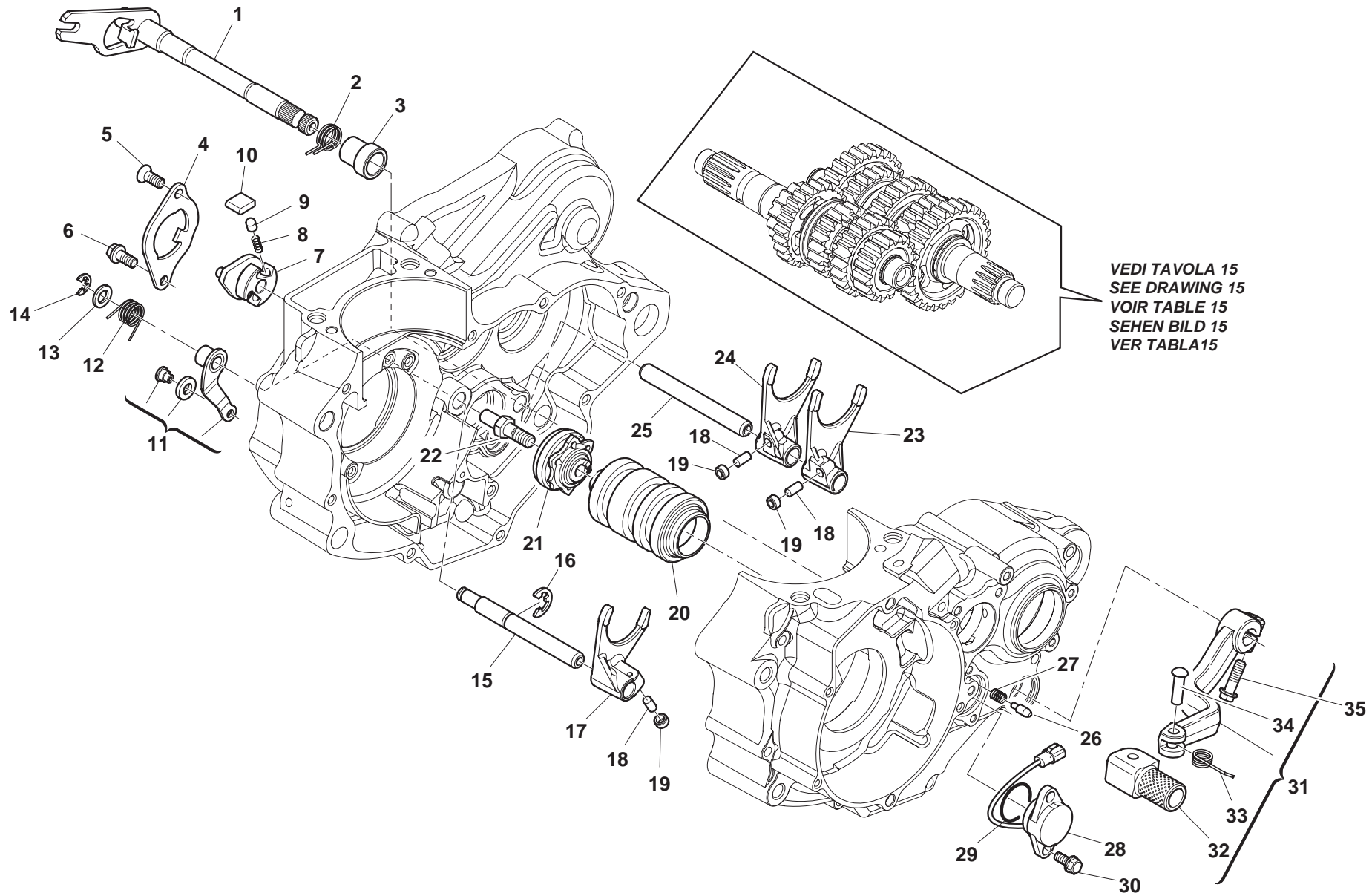

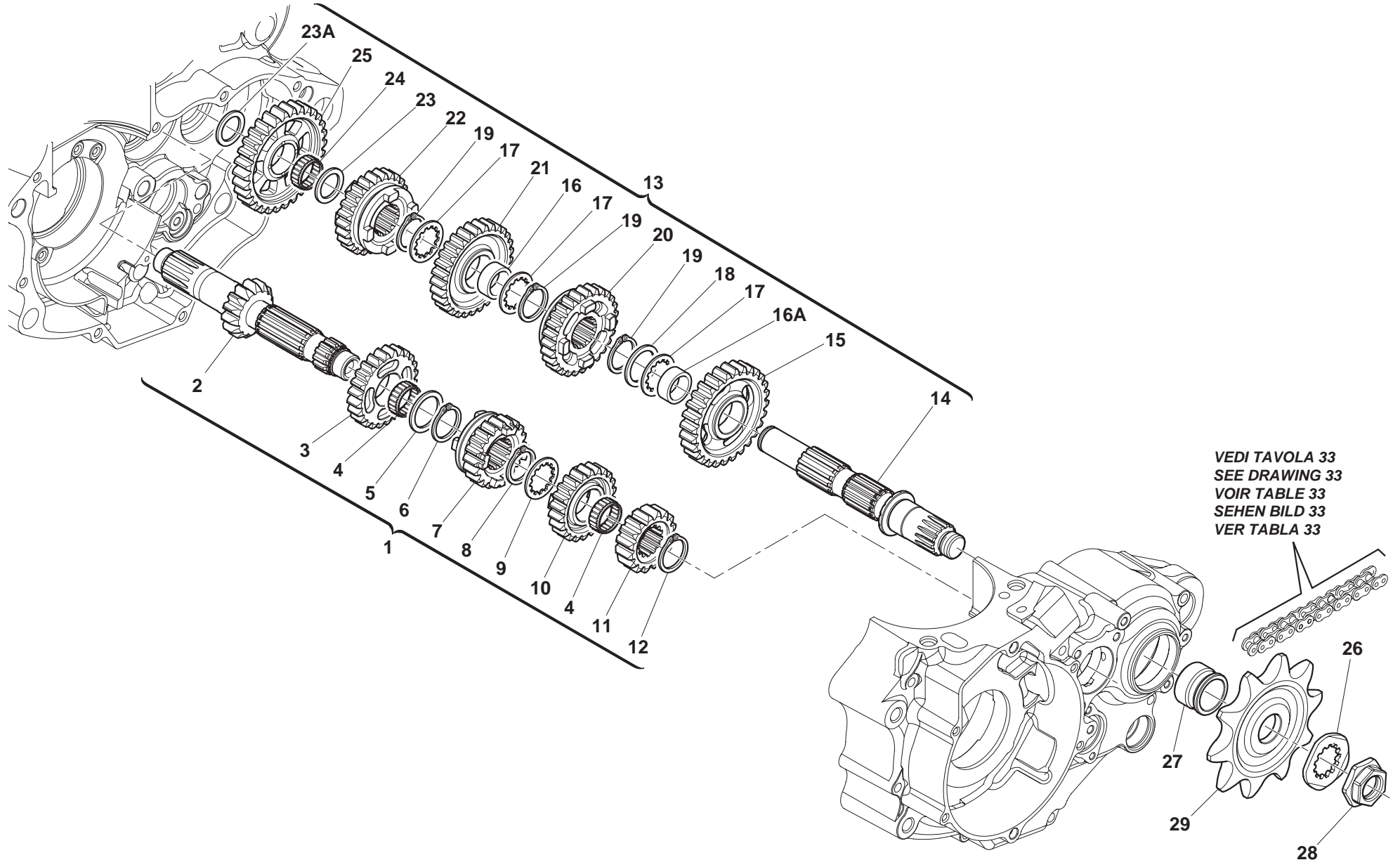

Note Notes Marke Notas	Pos. No. Index Pos.	N. Cod. Code No. Nr. Code Code Nr N. Cod.	Q.tà Qty Q.te M.ge C.ad	DENOMINAZIONE	NAME	DESIGNATION	BESHREIBUNG	DENOMINACION	Validità Validity Validité Gültig Validez
	1	8000 A7287	1	Ass.albero primario	Main shaft	Arbre primaire	Hauptwelle	Eje primario	
	2	8000 A7288	1	Albero primario (Z=14)	Main shaft (Z=14)	Arbre primaire (Z=14)	Hauptwelle (Z=14)	Eje primario (Z=14)	
	3	8000 A7289	1	Ingranaggio 5° sul primario (Z=24)	Gear 5th (Z=24)	Engrenage 5ème (Z=24)	Zahnrad 5° (Z=24)	Engranaje 5° (Z=24)	
	4	8000 A7099	2	Gabbietta a rullini	Rolls cage	Cage de rouleaux	Walzenkäfig	Jaula rodillos	
	5	8000 A7100	1	Rosetta	Washer	Rondelle	Scheibe	Arandela	
	6	8000 A7101	1	Anello elastico	Split ring	Anneau ressort	Sprengring	Anillo elástico	
	7	8000 A7290	1	Ingranaggio 3° sul primario (Z=20)	Main shaft 3rd gear (Z=20)	Engra. 3ème vitesse arbre prim.(Z=20)	Zahn.F.3. Geschw. Antriebsw. (Z=20)	Engra. 3° velocidad eje primario (Z=20)	
	8	66N0 21326	1	Anello seeger	Ring seeger	Bague seeger	Ring seeger	Anillo seeger	
	9	8000 A7116	1	Rosetta	Washer	Rondelle	Scheibe	Arandela	
	10	8000 A7291	1	Ingranaggio 4° sul primario (Z=22)	Main shaft 4th gear (Z=22)	Engra. 4ème vitesse arbre prim.(Z=22)	Zahn.F.4. Geschw. Antriebsw. (Z=22)	Engra. 4° velocidad eje primario (Z=22)	
	11	8000 A7292	1	Ingranaggio 2° sul primario (Z=16)	Main shaft 2nd gear (Z=16)	Engra. 2ème vitesse arbre prim.(Z=16)	Zahn.F.2. Geschw. Antriebsw. (Z=16)	Engra. 2° velocidad eje primario (Z=16)	
	12	66N0 21247	1	Anello elastico	Split ring	Anneau ressort	Sprengring	Anillo elástico	
	13	8000 A7294	1	Ass. albero secondario	Secondary shaft assy	Arbre secondaire	Neben welle	Arbol secundario	
	14	8000 A7295	1	Albero secondario	Secondary shaft	Arbre secondaire	Neben welle	Arbol secundario	
	15	8000 A7302	1	Ingranaggio 2° sul secondario (Z=28)	Secondary shaft 2nd gear (Z=28)	Engre. 2ème vitesse arbre secon.(Z=28)	Zah. f.2. Geschw. Vorgelegew (Z=28)	Engr. 2° velocidad Eje second.(Z=28)	
	16	8A00 A7348	1	Bussola	Bushing	Douille	Buchse	Manguito	
	16A	8000 A7348	1	Bussola	Bushing	Douille	Buchse	Manguito	
	17	8000 A7116	2	Rosetta scanalata	Washer	Rondelle	Scheibe	Arandela	
	18	8000 A7100	1	Rosetta	Washer	Rondelle	Scheibe	Arandela	
	19	66N0 21326	3	Anello seeger	Ring seeger	Bague seeger	Ring seeger	Anillo seeger	
	20	8000 A7301	1	Ingranaggio 4° sul secondario (Z=27)	Secondary shaft 4th gear (Z=27)	Engra. 4ème vitesse arbre secon.(Z=27)	Zah. f.4. Geschw. Vorgelegew (Z=27)	Engra. 4° velocidad Eje second.(Z=27)	
	21	8000 A7299	1	Ingranaggio 3° sul secondario (Z=29)	Secondary shaft 3rd gear (Z=29)	Engra. 3ème vitesse arbre secon.(Z=29)	Zah. f.3. Geschw. Vorgelegew (Z=29)	Engra. 3° velocidad Eje second.(Z=29)	
	22	8000 A7298	1	Ingranaggio 5° sul secondario (Z=25)	Secondary shaft 5th gear (Z=25)	Engra. 5ème vitesse arbre secon.(Z=25)	Zah. f.5. Geschw. Vorgelegew (Z=25)	Engra. 5° velocidad Eje second.(Z=25)	
	23	8A00 A7112	1	Rosetta (SP= 0,6 mm)	Washer (SP= 0,6 mm)	Rondelle (SP= 0,6 mm)	Scheibe (SP= 0,6 mm)	Arandela (SP= 0,6 mm)	
A	23A	8A00 A7348	1	Rosetta (SP= 0,6 mm)	Washer (SP= 0,6 mm)	Rondelle (SP= 0,6 mm)	Scheibe (SP= 0,6 mm)	Arandela (SP= 0,6 mm)	
A	23A	8000 A7112	1	Rosetta (SP= 0,5 mm)	Washer (SP= 0,5 mm)	Rondelle (SP= 0,5 mm)	Scheibe (SP= 0,5 mm)	Arandela (SP= 0,5 mm)	
	24	8000 A6597	1	Gabbietta a rullini	Rolls cage	Cage de rouleaux	Walzenkäfig	Jaula rodillos	
	25	8000 A7296	1	Ingranaggio 1° sul secondario (Z=30)	Secondary shaft 1st gear (Z=30)	Engre. 1ère vitesse arbre secon. (Z=30)	Zah. 1. Geschw. Vorgelegew (Z=30)	Engra. 1° velocidad Eje second. (Z=30)	
	26	8000 A7128	1	Rosetta di sicurezza	Washer	Rondelle	Scheibe	Arandela	
	27	8000 A7125	1	Distanziale	Spacer	Entretoise	Distanzstück	Separador	
	28	8000 A7129	1	Dado	Nut	Ecrou	Mutter	Tuerca	
S	29	8A00 A7126	1	Pignone uscita cambio (Z=13)	Pinion (Z=13)	Pignon (Z=13)	Ritzel (Z=13)	Pinon (Z=13)	
R	29	8000 A7126	1	Pignone uscita cambio (Z=12)	Pinion (Z=12)	Pignon (Z=12)	Ritzel (Z=12)	Pinon (Z=12)	

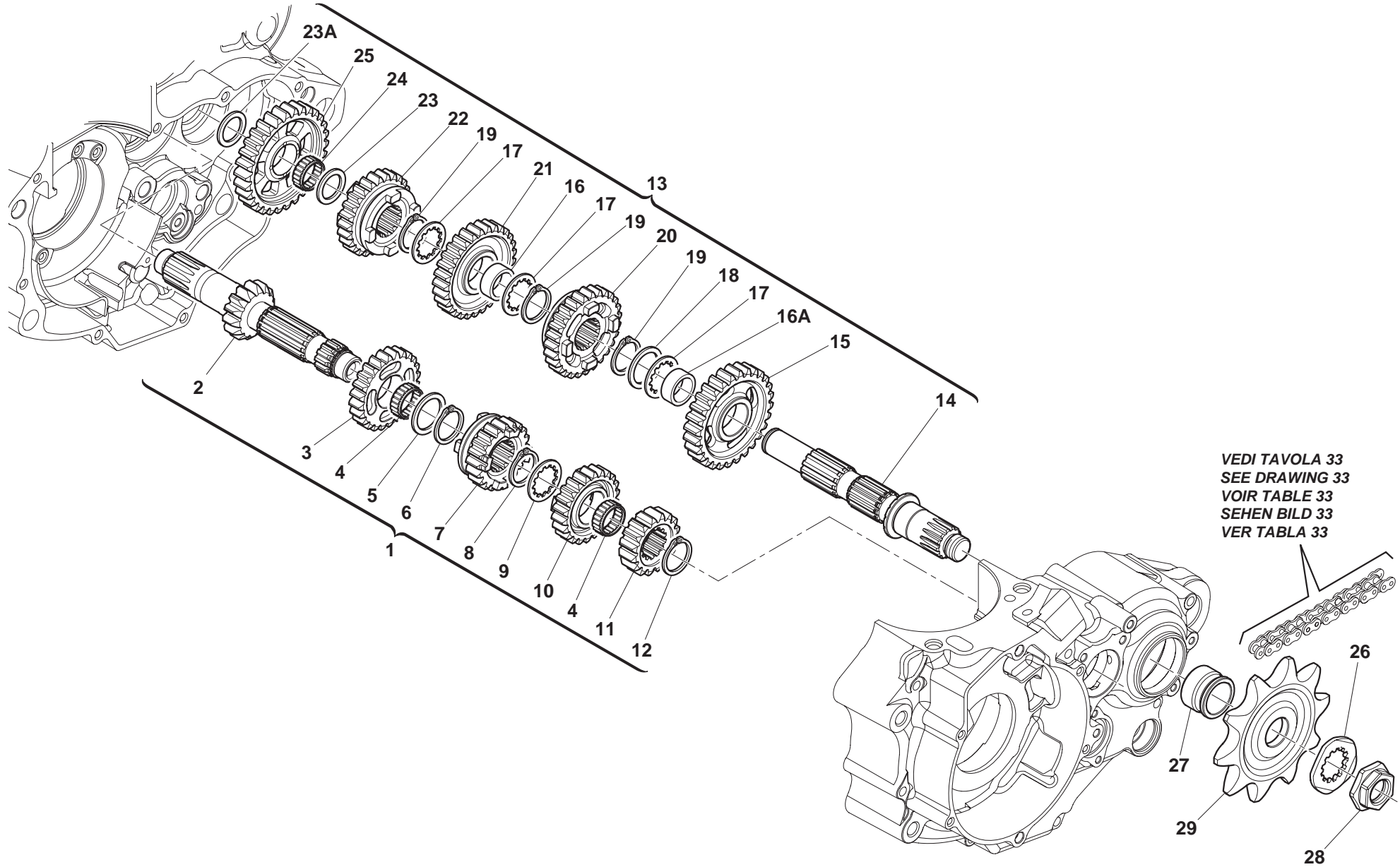



TC 250/2009

**CARBURATORE - CARBURETOR
 CARBURATEUR - VERGASER
 CARBURADOR**

(KEIHIN)

TAVOLA
 DRAWING
 TABLE
 BILD
 TABLA

16

Note Notes Notas	Pos. No. Index Pos.	N. Cod. CodeNo. Nr. Code Code Nr N. Cod.	Q.tà Qty Q.te M.ge C.ad	DENOMINAZIONE	NAME	DESIGNATION	BESHREIBUNG	DENOMINACION	Validità Validity Validité Gültig Validez
	1	8000 A6360	1	Carburatore 39	Carburettor 39	Carburateur 39	Vergaser 39	Carburador 39	
	2	8000 A7042	1	Cornetto presa aria	Pipe	Manchon	Muffe	Tubo toma aire	
	3	60N1 02482	2	Vite	Screw	Vis	Schraube	Tornillo	
	4	8000 36137	2	Rosetta	Washer	Rondelle	Scheibe	Arandela	
	5	8000 98215	1	Anello OR	O-Ring	Bague OR	O-Ring	Anillo OR	
	6	8000 A5616	1	Anello OR	O-Ring	Bague OR	O-Ring	Anillo OR	
	7	8A00 A5617	6	Vite	Screw	Vis	Schraube	Tornillo	
	8	8000 A5617	3	Vite	Screw	Vis	Schraube	Tornillo	
	13	8000 56444	2	Fascetta (L=188mm)	Clamp (L=188mm)	Collier (L=188mm)	Schelle (L=188mm)	Banda (L=188mm)	
	18	8000 A5618	1	Vite	Screw	Vis	Schraube	Tornillo	
	19	8000 H2019	1	Valvola gas 15	Throttle valve 15	Papillon de gaz 15	Drosselklappe 15	Válvula 15	
D	20	8000 A4295	1	Kit carburatore	Carburetor kit	Kit carburateur	Vergaser Kit	Kit carburador	
	21	8000 A5620	1	Sede guarnizione	Floating valve	Siège garniture	Dichtung Sitzring	Alojamento junta	
	22	8000 A5621	1	Guarnizione	Gasket	Garnitue	Dichtung	Junta	
	23	8000 98196	1	Spillo conico OBDVR	Needle OBDVR	Pointeau conique OBDVR	Kon. Nadel OBDVR	Pasador cónico OBDVR	
	24	8000 A5622	1	Anello seeger	Seeger ring	Bague seeger	Seegerring	Anillo Seeger	
	25	8000 A5623	1	Vite per spillo	Needle set screw	Vis pour pointeau conique	Kon. Nadel Schraube	Tornillo por pasador cónico	
	26	8000 H2020	1	Polverizzatore 6	Needle jet 6	Pulvériseur 6	Verstäuber 6	Pulverizador 6	
	27	8B00 98186	1	Getto massimo 190	Main jet 190	Gicleur principal 190	Hauptdüse 190	Chiclé máximo 190	
	28	8H00 A4624	1	Getto minimo 38	Idle jet 38	Gicleur minimum 38	Leerlaufdüse 38	Chiclé mínimo 38	
	29	8A00 98275	1	Getto starter 72	Starter jet 72	Gicleur starter 72	Starterdüse 72	Surtidor starter 72	
	30	8000 98268	1	Getto aria minimo 100	Slow running jet 100	Gicleur d'air ralenti 100	Leerlaufdüse 100	Chorro aire mínimo 100	
	36	8000 98272	1	Sede valvola	Valve seat	Siège soupape	Drosselsitz	Alojamento válvula	
	37	8000 A5625	1	Anello OR	O-Ring	Bague OR	O-Ring	Anillo OR	
	38	8000 A5626	1	Vite	Screw	Vis	Schraube	Tornillo	
	39	8000 H2021	1	Galleggiante	Float	Flotteur	Schwimmer	Flotador	
	40	8000 A5628	1	Perno	Pin	Pivot	Bolzen	Perno	
	42	8000 H2022	1	Valvola a spillo	Needle valve	Soupape à pointeau	Nadelventil	Válvula de aguja	
	43	8000 A5630	1	Molla per valvola a spillo	Needle valve clip	Ressort	Feder	Resorte	
	44	8000 A5631	1	Filtro	Filter	Filtre	Filter	Filtro	
	45	8000 A5632	1	Anello OR	O-Ring	Bague OR	O-Ring	Anillo OR	
	46	8000 A5633	1	Vite di spurgo	Drain screw	Vidange	Entleerung	Purga	
	51	8000 A5634	1	Diaframma	Diaphragm	Diaphragme	Biegeplatte	Diafragma	

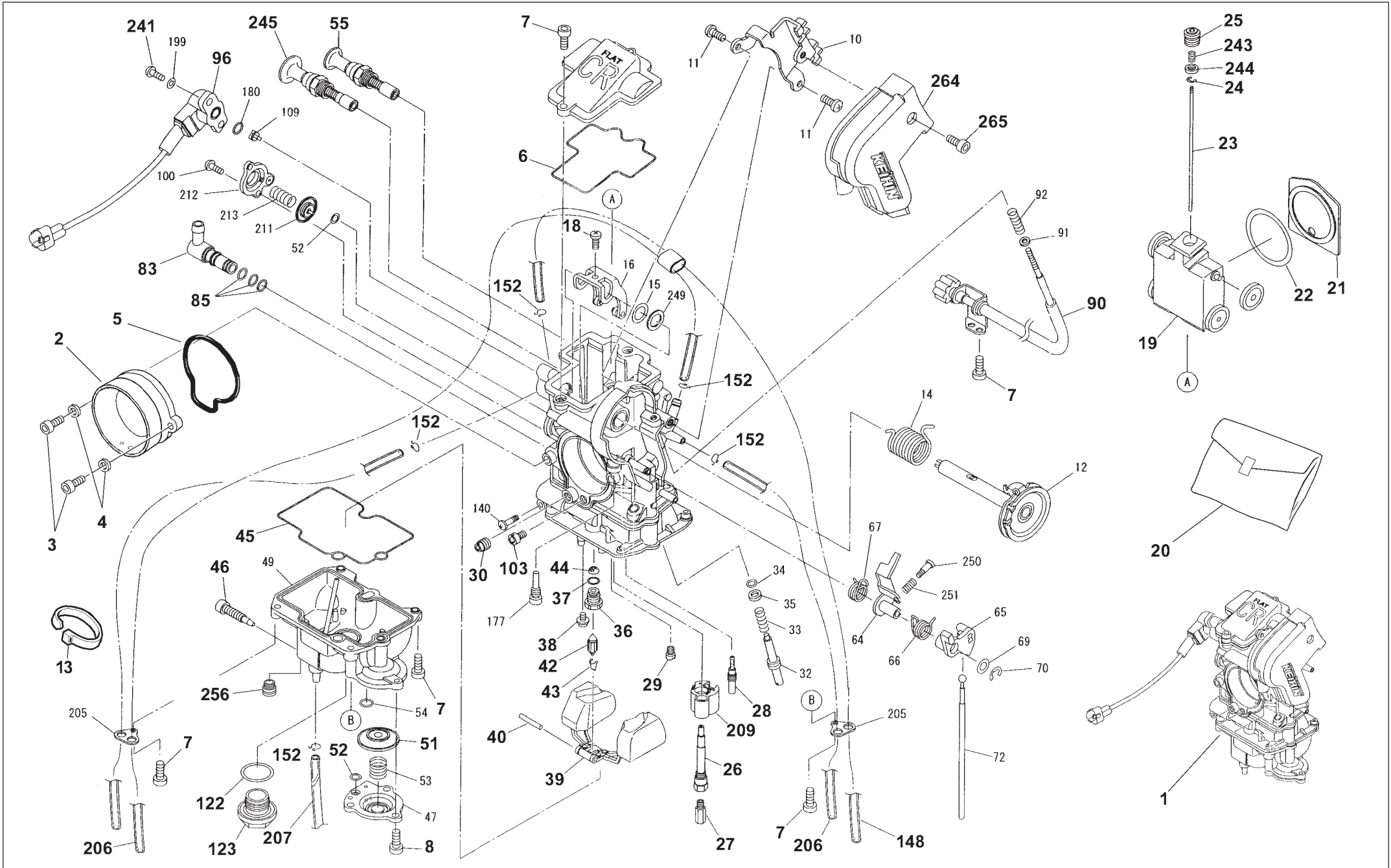

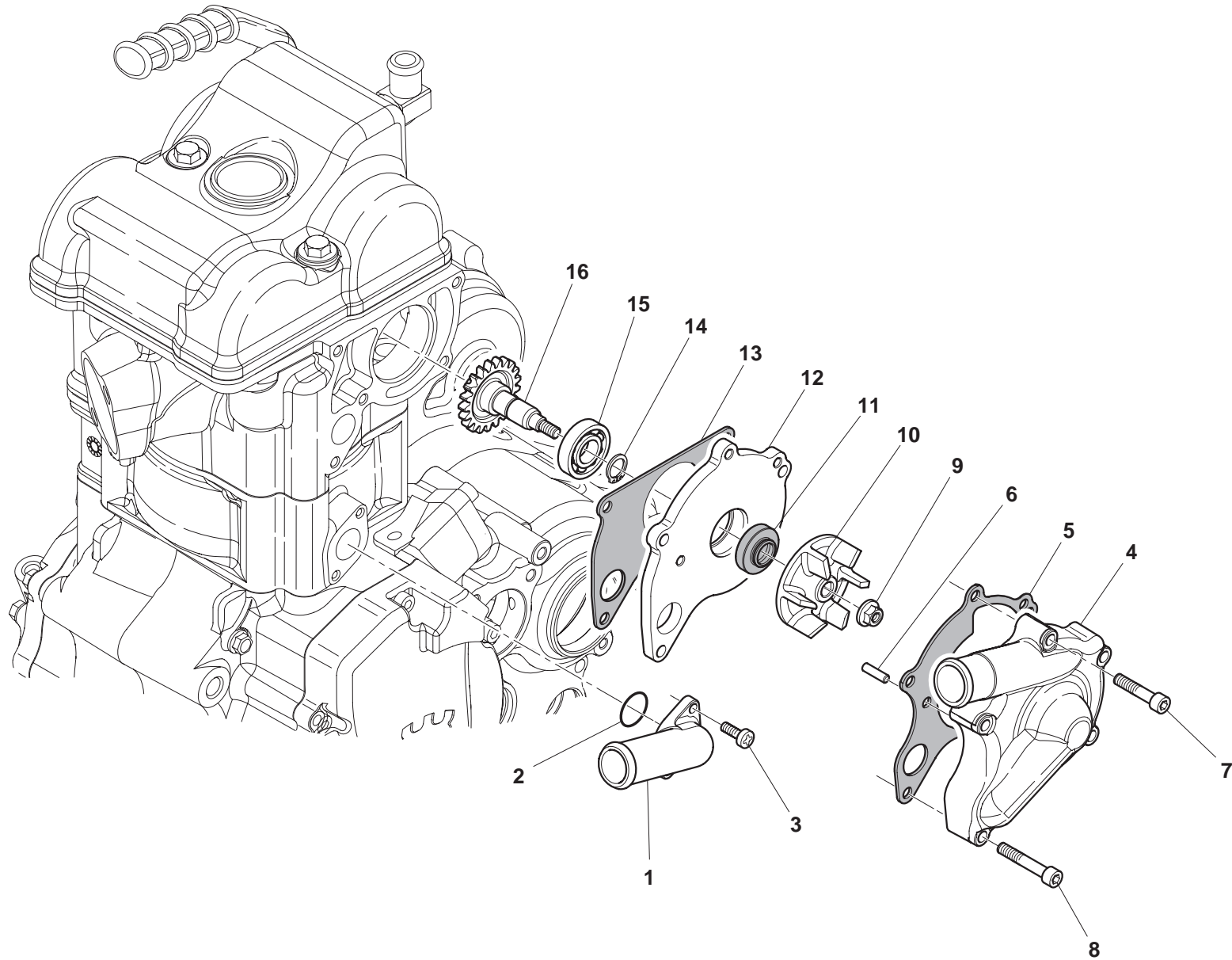



TC 250/2009

POMPA ACQUA - WATER PUMP POMPE EAU - WASSERPUMPE BOMBA AGUA

TAVOLA
DRAWING
TABLE
BLD
TABLA

17

Note Notes Notas	Pos. No. Index Pos.	N. Cod. CodeNo. Nr. Code Code Nr N. Cod.	Q.tà Qty Q.te M.ge C.ad	DENOMINAZIONE	NAME	DESIGNATION	BESHREIBUNG	DENOMINACION	Validità Validity Validité Gültig Validez
	1	8000 A7347	1	Raccordo per tubo	Union	Raccord	Verschraubung	Racor	
	2	8000 36380	1	OR	OR	OR	OR	OR	
	3	8A00 A6628	2	Vite M4-L12	Screw M4-L12	Vis M4-L12	Schraube M4-L12	Tornillo M4-L12	
	4	8000 A7344	1	Coperchio pompa	Pump cover	Couvercle pompe	Deckel	Cubierta bomba	
	5	8000 A7346	1	Guarnizione	Gasket	Garnitue	Dichtung	Junta	
	6	8000 A7012	2	Spina D4-L8	Dowel D4-L8	Plot D4-L8	Zylinderst D4-L8	Centraje D4-L8	
	7	60N1 02488	1	Vite M5-L25	Screw M5-L25	Vis M5-L25	Schraube M5-L25	Tornillo M5-L25	
	8	60N1 02489	4	Vite M5-L30	Screw M5-L30	Vis M5-L30	Schraube M5-L30	Tornillo M5-L30	
	9	8000 42278	1	Dado flangiato M5 dentellato	Nut M5	Ecrou M5	Mutter M5	Tuerca M5	
	10	8000 A7336	1	Girante	Impeller	Propulseur	Fluegelrad	Turbina impuls	
	11	8000 A7324	1	Anello	Ring	Bague	Ring	Anillo	
	12	8000 A7337	1	Corpo pompa acqua	Pump body	Corps pompe	Pumpenkörper	Corpo bomba	
	13	8000 A7338	1	Guarnizione corpo pompa	Gasket	Garnitue	Dichtung	Junta	
	14	66N0 21201	1	Anello elastico	Split ring	Anneau ressort	Sprengring	Anillo elástico	
	15	8000 28959	1	Cuscinetto D26-D10-SP8	Bearing D26-D10-SP8	Roulement D26-D10-SP8	Kugellager D26-D10-SP8	Cojinete D26-D10-SP8	
	16	8000 A7339	1	Albero pompa acqua	Pump shaft	Arbre pompe	Welle	Albor bomba	

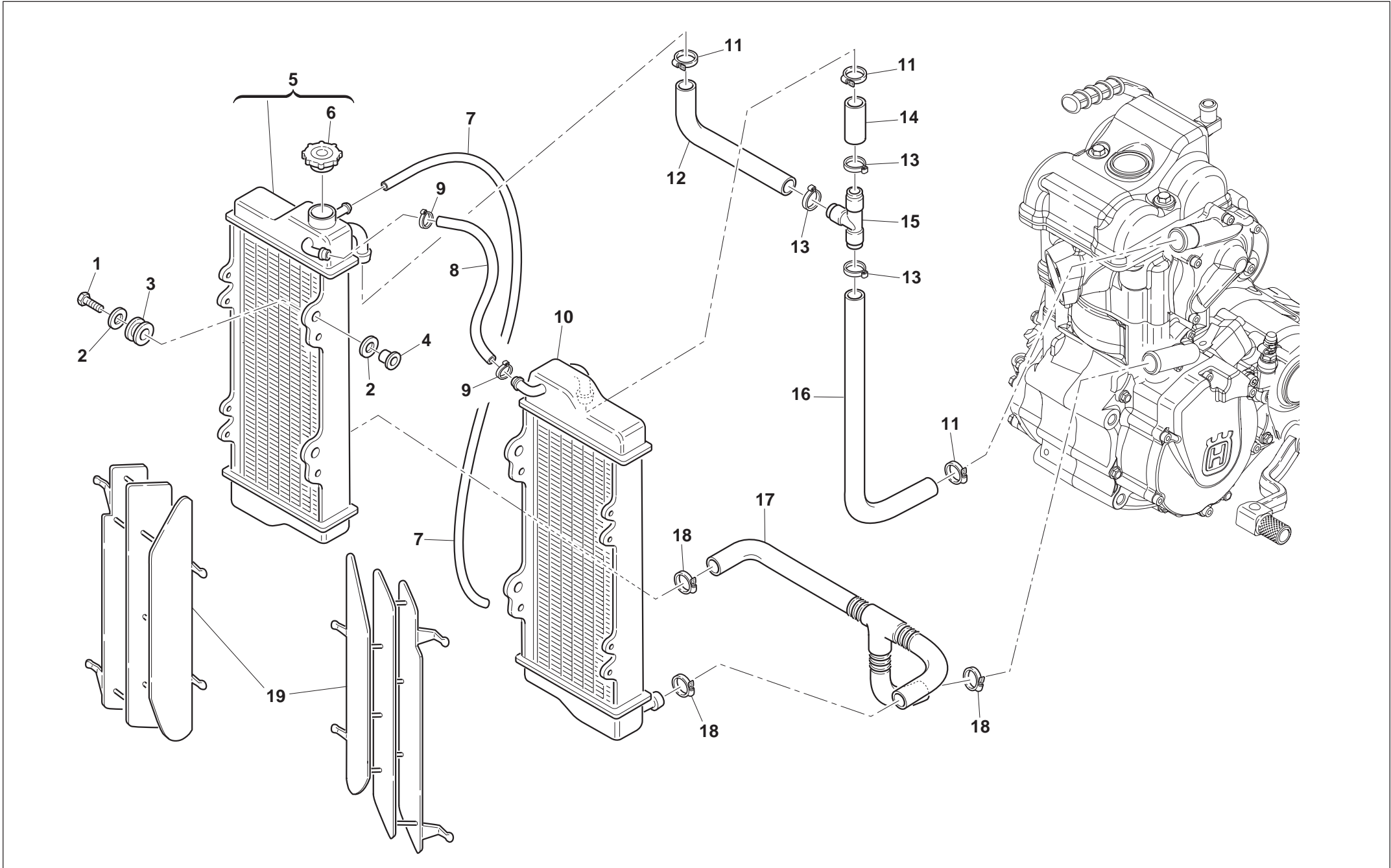

IMPIANTO DI RAFFREDDAMENTO - COOLING SYSTEM
INSTALLATION DE REFROIDISSEMENT - SCHMIERUNGSSYSTEM
EQUIPO DE ENFRIAMIENTO

Note Notes Mark Notas	Pos. No. N. Index Pos.	N. Cod. Code No. Nr. Code Code Nr N. Cod.	Q.tà Qty Q.te M.ge C.ad	DENOMINAZIONE	NAME	DESIGNATION	BESHREIBUNG	DENOMINACION	Validità Validity Validité Gültig Validez
	1	8000 62728	6	Vite M6-L20	Screw M6-L20	Vis M6-L20	Schraube M6-L20	Tornillo M6-L20	
	2	8000 59801	6	Rosetta piana	Washer	Rondelle	Scheibe	Arandela	
	3	8000 59803	6	Gommino	Rubber pad	Pièce caoutchouc	Gummistück	Junta de goma	
	4	8000 59802	6	Bussola	Bushing	Douille	Buchse	Manguito	
	5	8000 H0262	1	Radiatore Dx completo	R.H. radiator compl.	Radiateur D. compl.	R., Kühler	Radiador der. compl.	
	6	8000 H0260	1	Tappo	Plug	Bouchon	Verschluss	Tapón	
	7	8B00 43715	1	Tubetto sfiato	Tube	Tuyau	Rohr	Tubo	
	8	8F00 43716	1	Tubo	Pipe	Tuyau	Rohr	Tubo	
	9	8000 56462	2	Fascetta	Clamp	Collier	Schelle	Banda	
	10	800H 0261	1	Radiatore Sx	L.H. radiator	Radiateur G.	L., Kühler	Radiador iz.	
	11	8B00 99475	3	Fascetta	Clamp	Collier	Schelle	Banda	
	12	8000 B1610	1	Tubo Rad. Dx-Raccordo	Pipe	Tuyau	Schlauch	Tubo	
	13	8000 50453	3	Fascetta	Clamp	Collier	Schelle	Banda	
	14	8A00 A0669	1	Tubo Rad.Sx-Raccordo	Pipe	Tuyau	Schlauch	Tubo	
	15	8000 A0671	1	Raccordo	Union	Raccord	Anschluss	Empalme	
	16	8000 H0016	1	Tubo pompa-raccordo	Pipe	Tuyau	Schlauch	Tubo	
	17	8000 H0017	1	Tubo Inferiore Rad.	Pipe	Tuyau	Schlauch	Tubo	
	18	8A00 99475	3	Fascetta	Clamp	Collier	Schelle	Banda	
	19	8AA0 A0872	2	Griglia	Grid	Grille	Rost	Parilla	

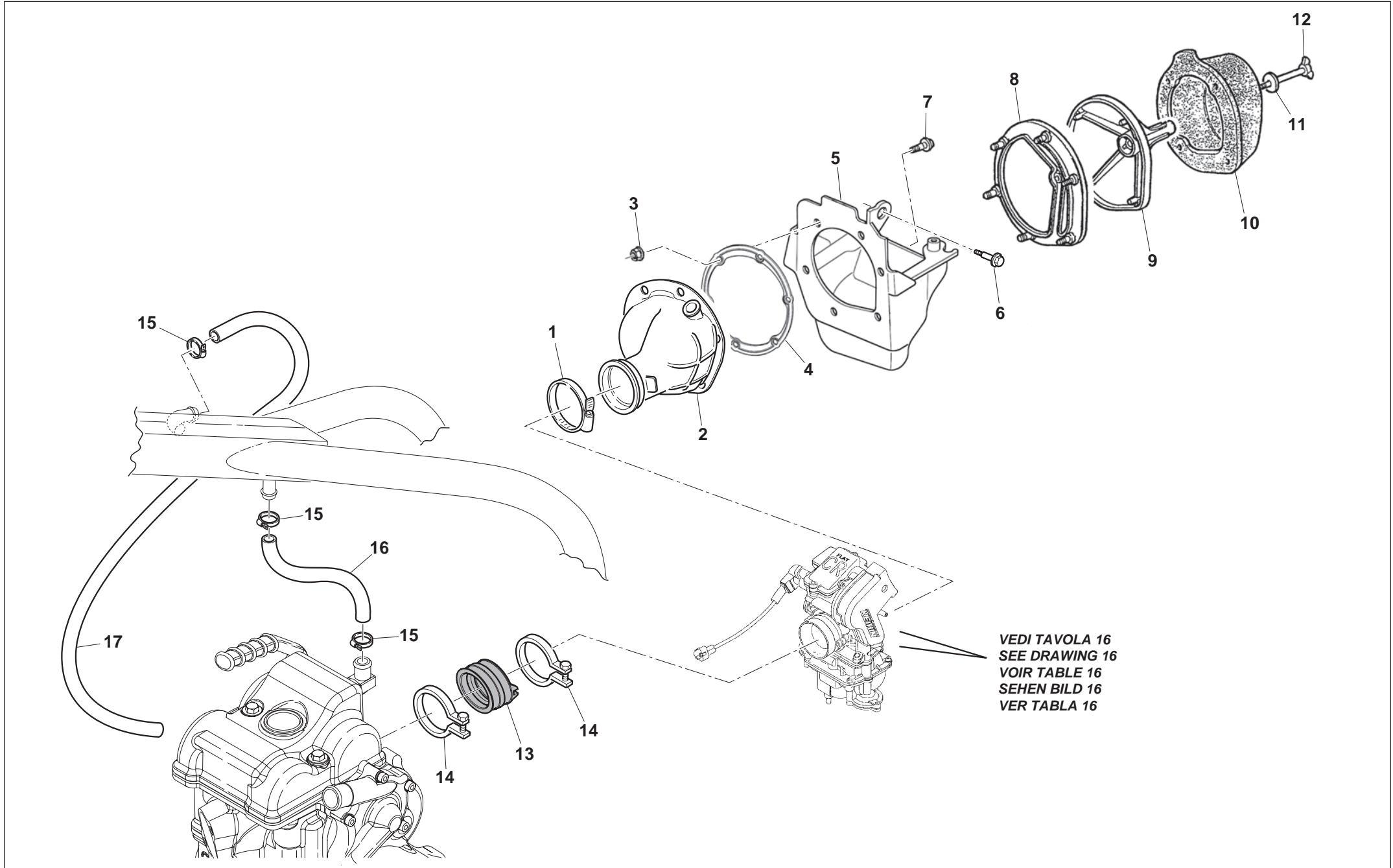

ASPIRAZIONE E FILTRO ARIA - AIR BOX AND FILTER
ASPIRATION ET FILTRE AIRE - ANSAUGEN UND LUFTFILTER
ASPIRACIÓN Y FILTRO DE AIRE

Note Notes Notas	Pos. No. Index Pos.	N. Cod. CodeNo. Nr. Code Code Nr N. Cod.	Q.tà Qty Q.te M.ge C.ad	DENOMINAZIONE	NAME	DESIGNATION	BESHREIBUNG	DENOMINACION	Validità Validity Validité Gültig Validez
	1	8E00 99475	1	Fascetta	Clamp	Collier	Schelle	Banda	
	2	8000 H0055	1	Raccordo	Union	Raccord	Anschluss	Empalme	
	3	8000 40718	6	Dado	Nut	Ecrou	Mutter	Tuerca	
	4	8000 B0575	1	Flangia	Flange	Bride	Flansch	Brida	
	5	8000 H0054	1	Scatola filtro aria	Air filter box	Boîte filtre	Filterkasten	Caja filtro aire	
	6	8A00 A8421	1	Vite M5-L12	Screw M5-L12	Vis M5-L12	Schraube M5-L12	Tornillo M5-L12	
	7	8B00 A8421	2	Vite M5-L16	Screw M5-L16	Vis M5-L16	Schraube M5-L16	Tornillo M5-L16	
	8	8000 70024	1	Flangia	Flange	Bride	Flansch	Brida	
	9	8000 69549	1	Gabbia filtro	Cleaner cage	Cage pour filtre	Filterkafig	Caja filtro	
	10	8000 72641	1	Filtro aria	Air filter	Filtre à air	Luftfilter	Filtro aire	
	11	62N1 15549	1	Rosetta piana	Washer	Rondelle	Scheibe	Arandela	
	12	8A00 37947	1	Vite	Screw	Vis	Schraube	Tornillo	
	13	8000 A7025	1	Raccordo carburatore-motore	Union	Raccord	Verschraubung	Racor	
	14	8000 A3774	2	Ass. Fascetta	Clamp	Collier	Halteschelle	Abrazadera	
	15	8A00 92249	3	Fascetta	Clamp	Collier	Halteschelle	Abrazadera	
	16	8000 H1439	1	Tubo sfiato olio	Breather pipe	Tuyau	Schutzrohr	Tubo	
	17	8A00 A0902	1	Tubo sfiato L=345	Breather pipe L=345	Tuyau L=345	Schutzrohr L=345	Tubo L=345	

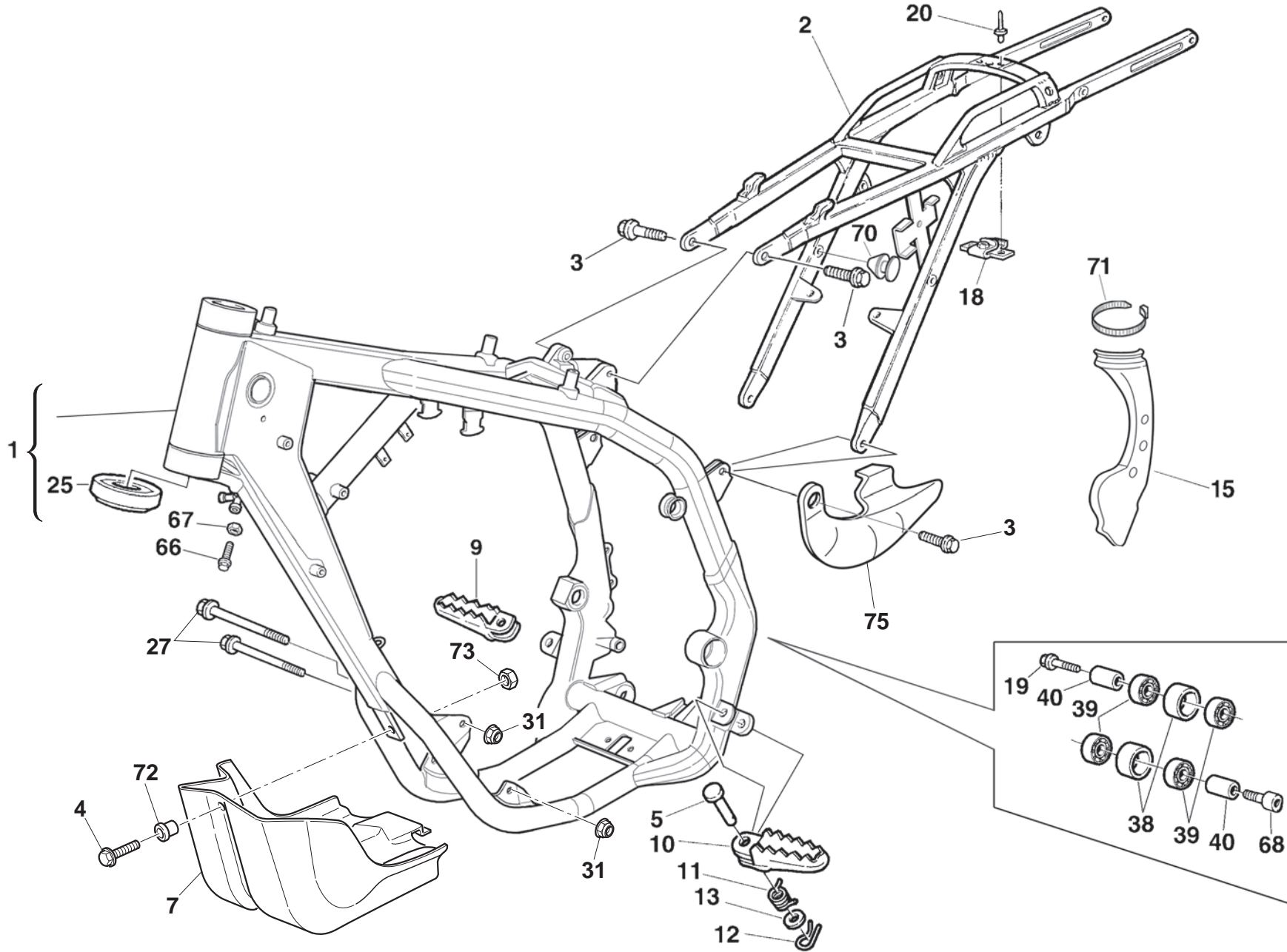

**TELAIO, PEDANE - FRAME, FOOT RESTS
CADRE, REPOSE PIEDS - RAHMEN, FUSSBRETT
BASTIDOR, REPOSAPIES**

Note Notes Marke Notas	Pos. No. Index Pos.	N. Cod. CodeNo. Nr. Code Code Nr N. Cod.	Q.tà Qty Q.te M.ge C.ad	DENOMINAZIONE	NAME	DESIGNATION	BESHREIBUNG	DENOMINACION	Validità Validity Validité Gültig Validez
	1	8A00 H0023	1	Telaio anteriore	Front frame	Chassis AV.	Rahmen vorrdrer	Bastidor delantero	
	2	8000 H0709	1	Telaio posteriore	Rear frame side	Chassis arrière	Sattelbrücke	Cuadro posterior	
	3	8000 69056	4	Vite M8-L20	Screw M8-L20	Vis M8-L20	Schraube M8-L20	Tornillo M8-L20	
D	4	8000 60898	1	Vite M6-L15	Screw M6-L15	Vis M6-L15	Schraube M6-L15	Tornillo M6-L15	
	5	8000 73140	2	Perno	Pin	Pivot	Bolzen	Perno	
D	7	8000 H0010	1	Paramotore	Engine guard	Garde moteur	Motorschutz	Para motor	
	9	80A0 89953	1	Pedana destra	R.H. foot-rest	Repose-pieds D.	R. Fussraste	Pedal delnt. derech. compl.	
	10	80A0 89962	1	Pedana sinistra	L.H. foot-rest	Repose-pieds G.	L. Fussraste	Pedal delant. izrdo. compl.	
	11	8000 96907	1	Molla Sx	L.H. spring	Ressort G.	Feder L.	Resorte Iz.	
	11	8000 96908	1	Molla Dx	R.H. spring	Ressort D.	Feder R.	Resorte Der.	
	12	64N1 20068	2	Copiglia	Split pin	Goupille	Splint	Clavija	
	13	8A00 01815	2	Rosetta	Washer	Rondelle	Scheibe	Arandela	
	15	80A0 B0245	1	Protezione telaio Sx	L.H. frame guard	Protection chassis G.	Rahmenschutz Links	Protección bastidor izquierda	
	18	8000 69150	1	Piastrina	Plate	Plaquette	Plättchen	Placa	
	19	8000 62796	1	Vite M8-L40	Screw M8-L40	Vis M8-L40	Schraube M8-L40	Tornillo M8-L40	
	20	8000 33373	2	Rivetto	Rivet	Rivet	Niet	Remache	
	25	8000 87243	2	Cuscinetto (d29-D48-17,5)	Bearing (29-48-17,5)	Roulement (29-48-17,5)	Kugellager (29-48-17,5)	Cojinete (29-48-17,5)	
	27	8N00 73458	2	Vite M8-L120	Screw M8-L120	Vis M8-L120	Schraube M8-L120	Tornillo M8-L120	
	31	8000 43928	2	Dado	Nut	Ecrou	Mutter	Tuerca	
	38	8AA0 59433	2	Rullo catena	Roller	Aiguille	Rolle	Rodillo	
	39	8000 63312	4	Cuscinetto (ø8xØ22x7 mm)	Bearing (ø8xØ22x7 mm)	Roulement (ø8xØ22x7 mm)	Kugellager (ø8xØ22x7 mm)	Cojinete (ø8xØ22x7 mm)	
	40	8A00 59434	2	Distanziale	Spacer	Entretoise	Distanzstück	Separador	
	66	8E00 61121	2	Vite M8-L30	Screw M8-L30	Vis M8-L30	Schraube M8-L30	Tornillo M8-L30	
	67	8000 17810	2	Dado	Nut	Ecrou	Mutter	Tuerca	
	68	60N1 02559	1	Vite	Screw	Vis	Schraube	Tornillo	
	70	8000 B0841	1	Tappo	Plug	Bouchon	Verschluss	Tapón	
	71	8000 56444	1	Fascetta (L=188mm)	Clamp (L=188mm)	Collier (L=188mm)	Schelle (L=188mm)	Banda (L=188mm)	
	72	80B0 69429	1	Bussola	Bushing	Douille	Buchse	Manguito	
	73	61N1 15062	1	Dado	Nut	Ecrou	Mutter	Tuerca	
	75	8000 B1747	1	Protezione calore	Heat protection	Protection thermique	Hitzeschutz	Protección calor	

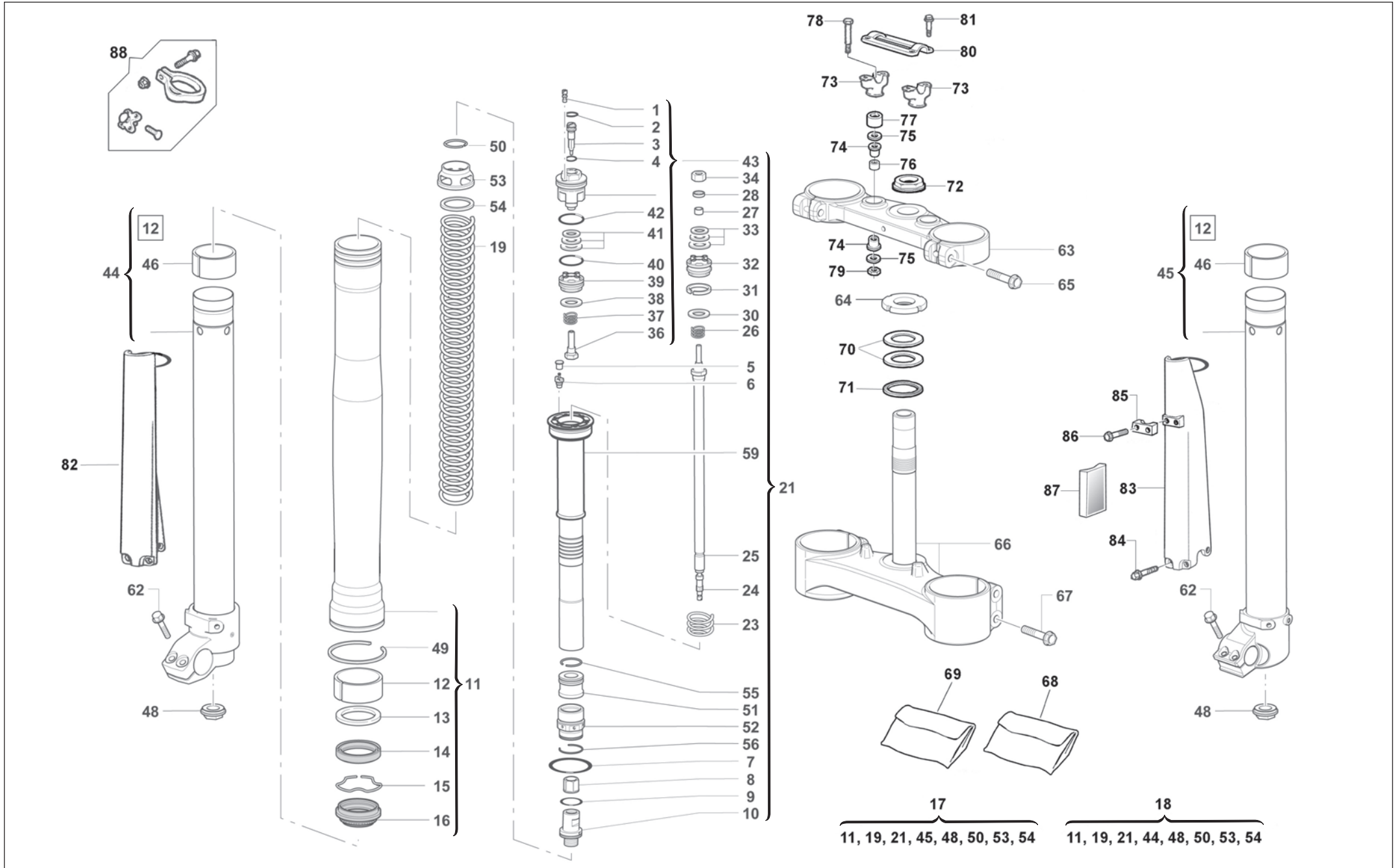

SOSPENSIONE ANTERIORE - FRONT FORK ASSEMBLY
SUSPENSION AVANT - VORDERTELESKOPGABEL
SUSPENSION DELANTERA

Note Notes Notas	Pos. No. Index Pos.	N. Cod. Code No. Nr. Code Code Nr N. Cod.	Q.tà Qty Q.te M.ge C.ad	DENOMINAZIONE	NAME	DESIGNATION	BESHREIBUNG	DENOMINACION	Validità Validity Validité Gültig Validez
	1		2	Vite	Screw	Vis	Schraube	Tornillo	
	2		2	Anello OR	O-Ring	Bague OR	O-Ring	Anillo OR	
	3		2	Vite	Screw	Vis	Schraube	Tornillo	
	4		2	Anello OR	O-Ring	Bague OR	O-Ring	Anillo OR	
	5		2	Tappo	Plug	Bouchon	Verschluss	Tapón	
	6		2	Vite	Screw	Vis	Schraube	Tornillo	
	7		2	Anello OR	O-Ring	Bague OR	O-Ring	Anillo OR	
	8		2	Dado	Nut	Ecrou	Mutter	Tuerca	
	9		2	Anello OR	O-Ring	Bague OR	O-Ring	Anillo OR	
	10		2	Gruppo registro	Adjuster set	Groupe réglage	Kupplungsreglergruppe	Grupo regul.	
	11	8000 H1069	2	Portastelo completo	Pipe assy	Groupe tuyau compl.	Rohrgruppe Kpl	Grupo tubo compl.	
	12	(a)	4	Bussola	Bushing	Douille	Buchse	Manguito	
	13		2	Scodellino	Cup	Cuvette	Teller	Cubeta	
	14	(b)	2	Anello di tenuta	Seal ring	Bague de retenue	Dichtring	Anillo de retención	
	15		2	Anello di fermo	Stop ring	Bague d'arrêt	Haltering	Anillo de retención	
	16	(b)	2	Raschiapolvere	Dust scraper	Racloir poudre	Pulverabschaber	Rascador de polvo	
	17	8000 H1993	1	Gamba Sx. compl.	L.H. fork leg assy	Fourche compl. G.	Telegabel, Kpl. L.	Horquill izrda. compl.	
	18	8000 H1992	1	Gamba Dx. compl.	R.H. fork leg assy	Fourche complete D.	Telegabel Kpl. R.	Horquilla derech. compl.	
	19	8000 H1994	2	Kit molla (K=4,8 N/mm)	Spring (K=4,8 N/mm)	Ressort (K=4,8 N/mm)	Feder (K=4,8 N/mm)	Resorte (K=4,8 N/mm)	
	21	8000 H1071	2	Gruppo pompante compl.	Damping element compl.	Amortissement compl.	Schwingungsdämpfer Kpl.	Bombardora compl.	
	23		2	Molla	Spring	Ressort	Feder	Resorte	
	24		2	Asta interna	Internal rod	Barre	Stange	Varilla	
	25		2	Ass. asta	Rod assy	Barre compl.	Stange Kpl	Grupo varilla	
	26		2	Molla	Spring	Ressort	Feder	Resorte	
	27		2	Tampone di fondo	Pad	Tampon	Stopfen	Tampón	
	28		2	Anello di tenuta	Seal ring	Bague de retenue	Dichtring	Anillo de retención	
	30		2	Lamella	Plate	Lamelle	Plättchen	Laminilla	
	31		2	Segmento	Circlip	Segment	Kolbenring	Segmento	
	32		2	Pistone estensione	R.H. piston	Piston D.	Kolbe R.	Pistón der.	
	33		6	Lamella	Plate	Lamelle	Plättchen	Laminilla	
	34		2	Dado	Nut	Ecrou	Mutter	Tuerca	
	36		2	Vite	Screw	Vis	Schraube	Tornillo	
	37		2	Molla	Spring	Ressort	Feder	Resorte	

SOSPENSIONE ANTERIORE - FRONT FORK ASSEMBLY
SUSPENSION AVANT - VORDERTELESKOPGABEL
SUSPENSION DELANTERA

Note Notes Marke Notas	Pos. No. Index Pos.	N. Cod. CodeNo. Nr. Code Code Nr N. Cod.	Q.tà Qty Q.te M.ge C.ad	DENOMINAZIONE	NAME	DESIGNATION	BESHREIBUNG	DENOMINACION	Validità Validity Validité Gültig Validez
	38		2	Lamella	Plate	Lamelle	Plättchen	Laminilla	
	39		2	Pistone estensione	R.H. piston	Piston D.	Kolbe R.	Pistón der.	
	40		2	Anello OR	O-Ring	Bague OR	O-Ring	Anillo OR	
	41		6	Lamella	Plate	Lamelle	Plättchen	Laminilla	
	42		2	Anello OR	O-Ring	Bague OR	O-Ring	Anillo OR	
	43	8000 H1072	2	Gruppo tappo	Plug assy.	Groupe bouchon	Verschlussgruppe Kpl.	Grupo tapón	
	44	8000 B1694	1	Stelo Dx. compl.	R.H. slider assy	Montant D. compl.	Bein, Kpl. R.	Deslizable der. compl.	
	45	8000 B1693	1	Stelo Sx. compl.	L.H. slider assy	Montant G. compl.	Bein, Kpl. L.	Deslizable izrda. compl.	
	46	(a)	2	Bussola	Bushing	Douille	Buchse	Manguito	
	48	8000 H1073	2	Dado	Nut	Ecrou	Mutter	Tuerca	
	49		2	Anello di fermo	Stop ring	Bague d'arrêt	Haltering	Anillo de retención	
	50		2	Anello OR	O-Ring	Bague OR	O-Ring	Anillo OR	
	51		2	Bussola	Bushing	Douille	Buchse	Manguito	
	52		2	Bussola	Bushing	Douille	Buchse	Manguito	
	53		2	Tappo	Plug	Bouchon	Verschluss	Tapón	
	54		2	Scodellino	Cup	Cuvette	Teller	Cubeta	
	55		2	Anello OR	O-Ring	Bague OR	O-Ring	Anillo OR	
	56		2	Anello OR	O-Ring	Bague OR	O-Ring	Anillo OR	
	59		2	Cartuccia	Cartridge	Cartouche	Patrone	Cartucho	
	62	8000 62729	4	Vite M6-L25	Screw M6-L25	Vis M6-L25	Schraube M6-L25	Tornillo M6-L25	
	63	8000 A5961	1	Testa di sterzo	Steering head	Tête direction	Lenkkopf	Cabezal de dirección	
	64	8A00 87717	1	Ghiera registro cuscinetti	Ring nut	Embout	Nutmutter	Virola	
	65	8000 62733	2	Vite M8-L35	Screw M8-L35	Vis M8-L35	Schraube M8-L35	Tornillo M8-L35	
	66	8A00 B0439	1	Base di sterzo con perno	Steering crown with pin	Socle de direction avec pivot	Gabelbrücke mit Bolzen	Base de dirección con perno	
	67	8000 62796	4	Vite M8-L40	Screw M8-L40	Vis M8-L40	Schraube M8-L40	Tornillo M8-L40	
	68	8000 A7592	1	Kit anelli di tenuta	Seal ring kit	Kit bague de retenue	Dichtringkit	Kit anillo de retención	
	69	8000 A7593	1	Kit boccole	Bush kit	Kit douille	Buchsekit	Kit manguito	
	70	8000 87745	2	Guarnizione di tenuta	Gasket	Garniture	Dichtung	Junta	
	71	8000 87736	1	Rosetta piana	Washer	Rondelle	Scheibe	Arandela	
	72	8A00 69315	1	Dado	Nut	Ecrou	Mutter	Tuerca	
	73	8A00 A5879	2	Morsetto inferiore	Lower clamp	Etrier inf.	Untere Brücke	Brida inf.	
	74	8000 60233	4	Gommino	Rubber pad	Pièce caoutchouc	Gummistück	Junta de goma	
	75	8000 60234	4	Rosetta piana	Washer	Rondelle	Scheibe	Arandela	

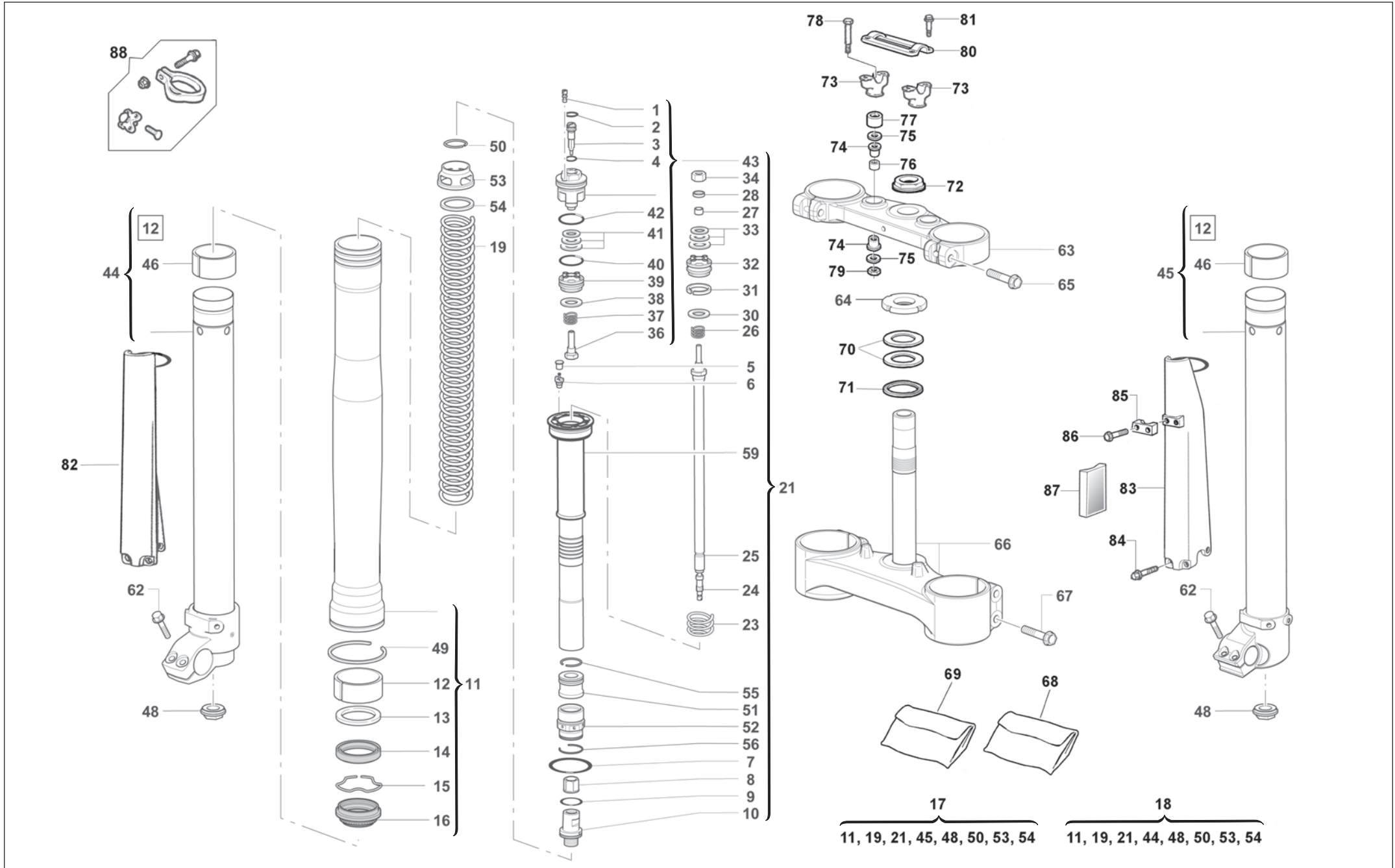

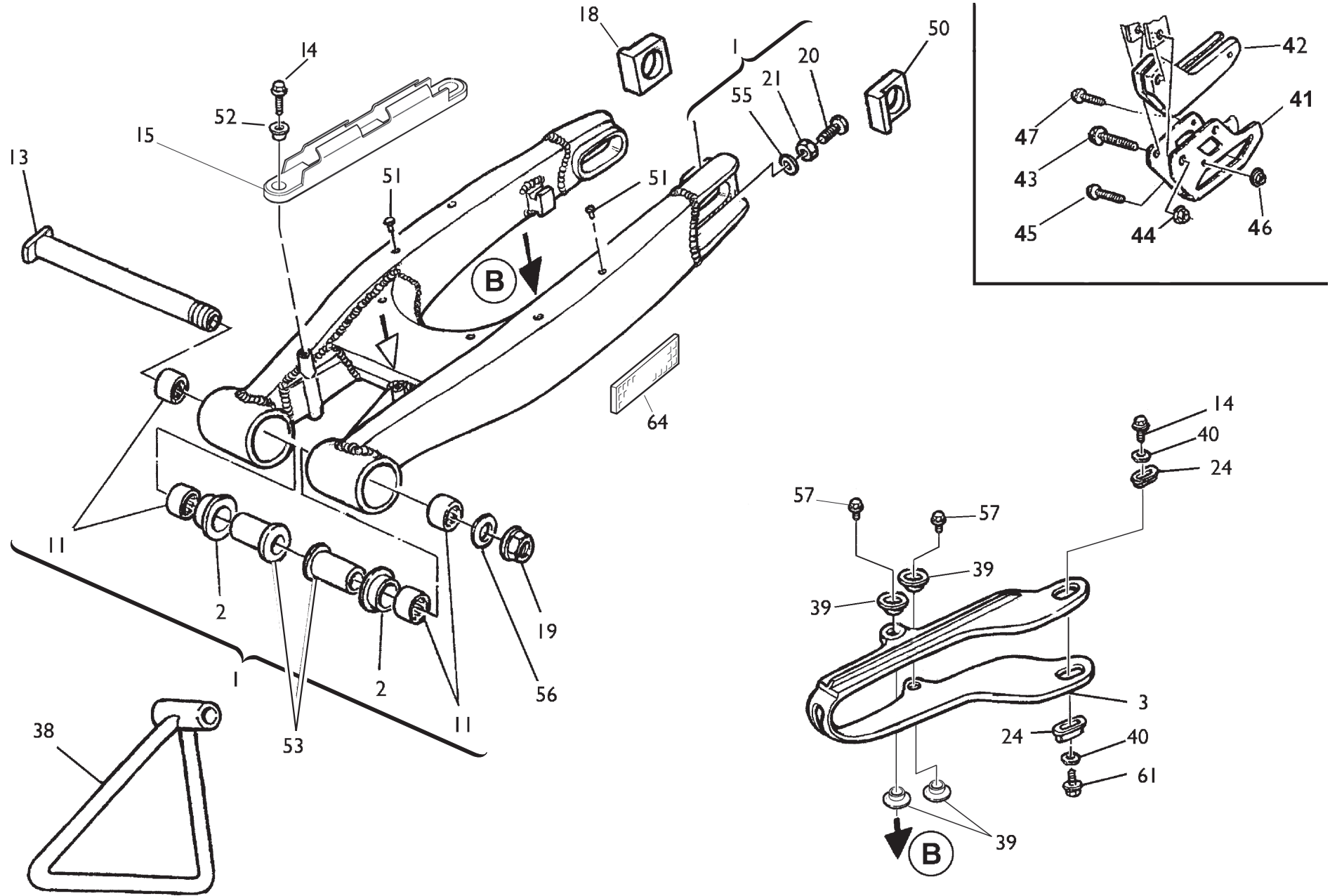

FORCELLONE POSTERIORE- REAR SWING ARM- FOURCHE ARRIERE - HINTERGABEL HORQUILLA TRASERA

Note Notes Marke Notas	Pos. No. N. Index Pos.	N. Cod. CodeNo. Nr. Code Code Nr N. Cod.	Q.tà Qty Q.te M.ge C.ad	DENOMINAZIONE	NAME	DESIGNATION	BESHREIBUNG	DENOMINACION	Validità Validity Validité Gültig Validez
	1	8000 H0680	1	Forcellone completo	Compl. fork	Fourche complete	Gabel, Kpl.	Horquilla compl.	
	2	8000 71622	2	Bussola	Bushing	Douille	Buchse	Manguito	
	3	80A0 99619	1	Pattino catena	Chain slider	Glissière de chaîne	Gleitbahn	Platode cadena	
	11	8000 76283	4	Gabbia a rullini	Needle cage	Cage à aiguilles	Nadelkaefig	Jaula de agujas del cojinete	
	13	8A00 71620	1	Perno forcellone	Fork pin	Pivot fourche	Gabelbolzen	Perno horquilla	
	14	8000 20536	3	Vite	Screw	Vis	Schraube	Tornillo	
	15	8000 B1166	1	Guida tubo	Guide ring	Bague de guide	Rohrring	Guía-cable	
	18	8000 96944	1	Tendicatena DX	Chain adjuster Right	Tendeur de chaîne Droite	Kettenspanner R.	Tensor de cadena Derecha	
	19	8000 71623	1	Dado	Nut	Ecrou	Mutter	Tuerca	
	20	ZC00 61121	2	Vite	Screw	Vis	Schraube	Tornillo	
	21	Z000 17810	2	Dado	Nut	Ecrou	Mutter	Tuerca	
	24	8000 59289	2	Scodellino	Cup	Cuvette	Teller	Cubeta	
D	38	8000 74016	1	Gamba laterale	Side stand	Bequille lat.	Seitenständer	Horquilla lateral	
	39	8000 75166	4	Scodellino	Cup	Cuvette	Teller	Cubeta	
	40	8000 36137	2	Rosetta	Washer	Rondelle	Scheibe	Arandela	
	41	8000 72869	1	Staffa	Bracket	Etrier	Buegel	Brida	
	42	8000 72868	1	Guidacatena	Chain guide	Guide-chaîne	Kettenführung	Guía-cadena	
	43	8000 62795	1	Vite M8-L50	Screw M8-L50	Vis M8-L50	Schraube M8-L50	Tornillo M8-L50	
	44	8000 43928	1	Dado M8	Nut M8	Ecrou M8	Mutter M8	Tuerca M8	
	45	8000 62731	1	Vite M6-L45	Screw M6-L45	Vis M6-L45	Schraube M6-L45	Tornillo M6-L45	
	46	8000 44240	1	Dado M6	Nut M6	Ecrou M6	Mutter M6	Tuerca M6	
	47	8000 62725	1	Vite M6-L10	Screw M6-L10	Vis M6-L10	Schraube M6-L10	Tornillo M6-L10	
	50	8000 96941	1	Tendicatena Sx	Chain adjuster Left	Tendeur de chaîne Gouche	Kettenspanne L.	Tensor de cadena Izquierda	
	51	8000 75160	7	Rivetto	Rivet	Rivet	Niet	Remache	
	52	8000 69282	2	Bussola	Bushing	Douille	Buchse	Manguito	
	53	8000 71621	1	Bussola (L= 49,5 mm) Sx	Bushing (L= 49,5 mm) Left	Douille (L= 49,5 mm) Gouche	Buchse (L= 49,5 mm) SX	Manguito (L= 49,5 mm) Izquierda	
	53	8A00 71621	1	Bussola (L= 58,5 mm) Dx	Bushing (L= 58,5 mm)Right	Douille (L= 58,5 mm) Droite	Buchse (L= 58,5 mm) DX	Manguito (L= 58,5 mm) Derecha	
	55	8000 08536	2	Rosetta piana	Washer	Rondelle	Scheibe	Arandela	
	56	8000 32388	1	Rosetta	Washer	Rondelle	Scheibe	Arandela	
	57	8000 67997	2	Vite M5-L12	Screw M5-L12	Vis M5-L12	Schraube M5-L12	Tornillo M5-L12	
	61	8000 20536	3	Vite	Screw	Vis	Schraube	Tornillo	
	64	8000 73832	2	Catadiottro (CDN)	Reflector (CDN)	Catadioptrique (CDN)	Rückstrahler (CDN)	Catafaros (CDN)	

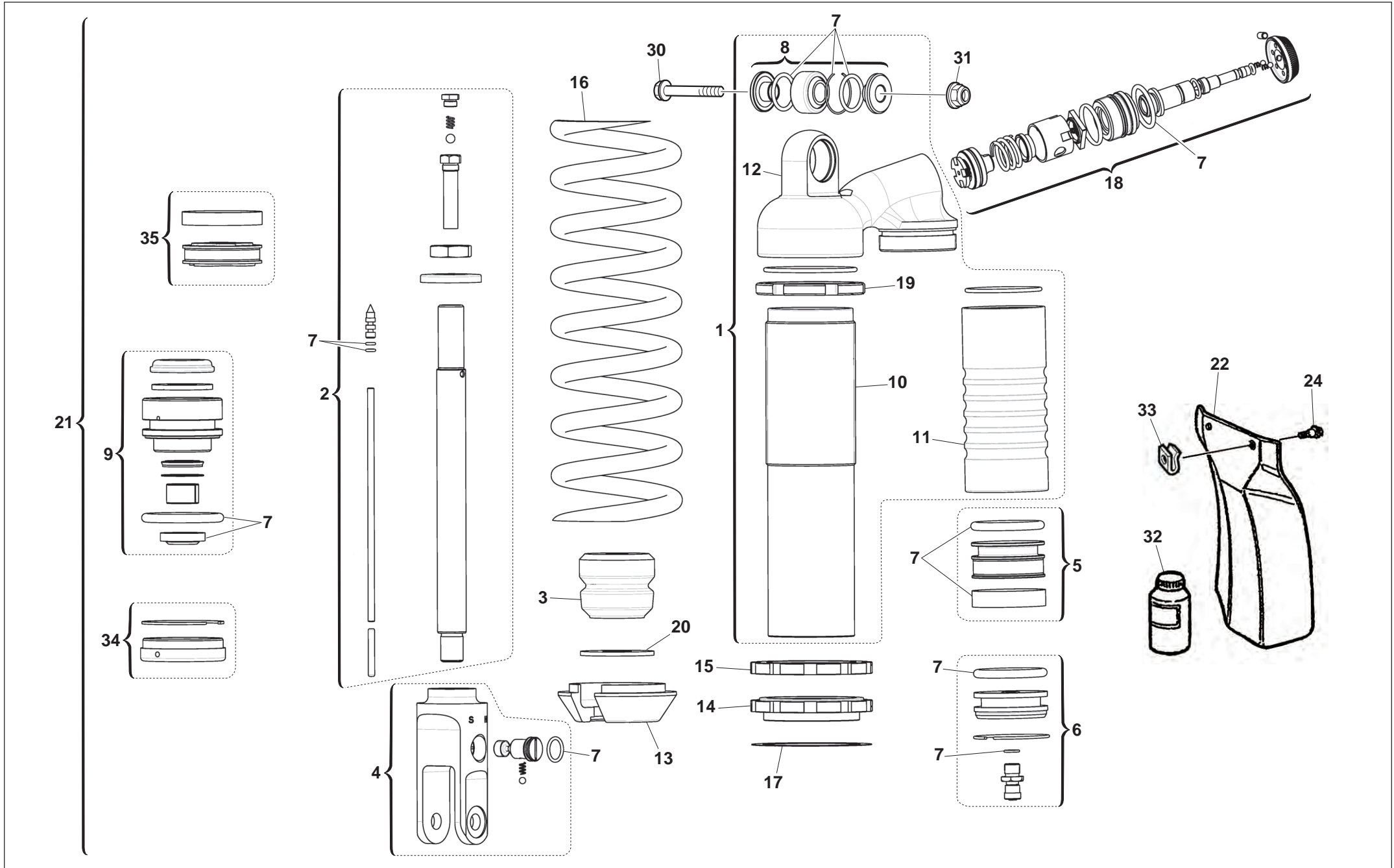

AMMORTIZZATORE POSTERIORE- REAR SUSPENSION SUSPENSION ARRIERE- HINTERHAUFHANGUNG SUSPENSION TRASERA

Note Notes Marke Notas	Pos. No. Index Pos.	N. Cod. Code No. Nr. Code Code Nr N. Cod.	Q.tà Qty Q.te M.ge C.ad	DENOMINAZIONE	NAME	DESIGNATION	BESHREIBUNG	DENOMINACION	Validità Validity Validité Gültig Validez
	1	8000 H0069	1	Gruppo corpo	Damper case assy	Groupe corps ammortisseur	Stossdämpferkörper Kpl.	Corpo amortiguador compl.	
	2	8000 H2026	1	Gruppo stelo	Rod assy	Groupe tige	Pumpenstückgruppe	Grupo espiga	
	3	8000 A6670	1	Tampone	Pad	Tampon	Stopfen	Tampón	
	4	8000 H0071	1	Gruppo forcella	Fork assy	Groupe fourche	Gabelgruppe Kpl.	Grupo horquilla	
	5	8000 A5071	1	Diaframma	Diaphragm	Diaphragme	Biegeplatte	Diafragma	
	6	8000 98491	1	Gruppo tappo	Plug assy	Groupe bouchon	Verschlussgruppe Kpl	Grupo tapón	
	7	8000 H2027	1	Gruppo guarnizioni	Gasket set	Groupe garnitures	Dichtungssatz	Grupo juntas	
	8	8000 89089	1	Gruppo snodo	Ball joint assy	Groupe joint a rotule	Kugelgelenkgruppe Kpl.	Grupo articulaciòn esferica	
	9	8000 H1051	1	Gruppo guida stelo	Guide rod assy	Groupe guide tige	Pumpenstückführungsgruppe	Grupo guja espiga	
	10	8000 H0074	1	Corpo ammortizzatore	Damper case	Corps ammortisseur	Stossdämpferkörper	Corpo amortiguador	
	11	8000 B1920	1	Serbatoio	Tank	Reservoir	Tank	Deposito	
	12	8000 H0075	1	Supporto serbatoio	Tank support	Support reservoir	Gastankhalterung	Soporte deposito	
	13	8000 98496	1	Fondello	Bottom	Fond	Bodenscheibe	Casquillo	
	14	8000 98497	1	Ghiera	Ring nut	Embout	Nutmutter	Virola	
	15	8000 98498	1	Controghiera	Ring nut	Embout	Nutmutter	Virola	
	16	8000 98504	1	Molla (k=5,4 Kg/mm)	Spring (k=5,4 Kg/mm)	Ressort (k=5,4 Kg/mm)	Feder (k=5,4 Kg/mm)	Resorte (k=5,4 Kg/mm)	
	17	8000 98499	1	Rosetta per molla	Washer	Rondelle	Scheibe	Arandela	
	18	8000 B1922	1	Gruppo regolazione	Adjuster set	Groupe réglage	Reglergruppe Kpl.	Grupo regulacion	
	19	8000 B1923	1	Ghiera	Ring nut	Embout	Nutmutter	Virola	
	20	8000 H0077	1	Rosetta	Washer	Rondelle	Scheibe	Arandela	
	21	8000 H0001	4	Ammortizzatore completo	Shock-absorber	Ammortisseur	Stossdämpfer	Amortiguador	
	22	8000 69551	1	Protezione ammortizzatore	Guard	Protection	Schutz	Protección	
	24	8000 A8421	2	Vite flangiata M5-L8	Flange bolt M5-L8	Boulon de bride M5-L8	Flanschenschraube M5-L8	Perno de reborde M5-L8	
	30	8000 62573	1	Vite M10-L40	Screw M10-L40	Vis M10-L40	Schraube M10-L40	Tornillo M10-L40	
	31	8000 42022	1	Dado	Nut	Ecrou	Mutter	Tuerca	
R	32	8000 88231	1	Olio ammortizzatore	Shock-absorber oil	Huile ammortisseur	Öl für Stossdämpfer	Aceite amortiguador	
	33	8000 55134	2	Dado a graffetta	Nut	Ecrou	Mutter	Tuerca	
	34	8000 H1055	1	Gruppo tappo ammortizzatore	Shock-absorber plug assy	Groupe bouchon ammortisseur	Verschlussgruppe Kpl.	Grupo tapón amortiguador	
	35	8000 H1056	1	Gruppo pistone + segmento	Piston assy + segment	Groupe piston + segment	Kolben Kpl. + kolbenring	Grupo pistón + segmento	

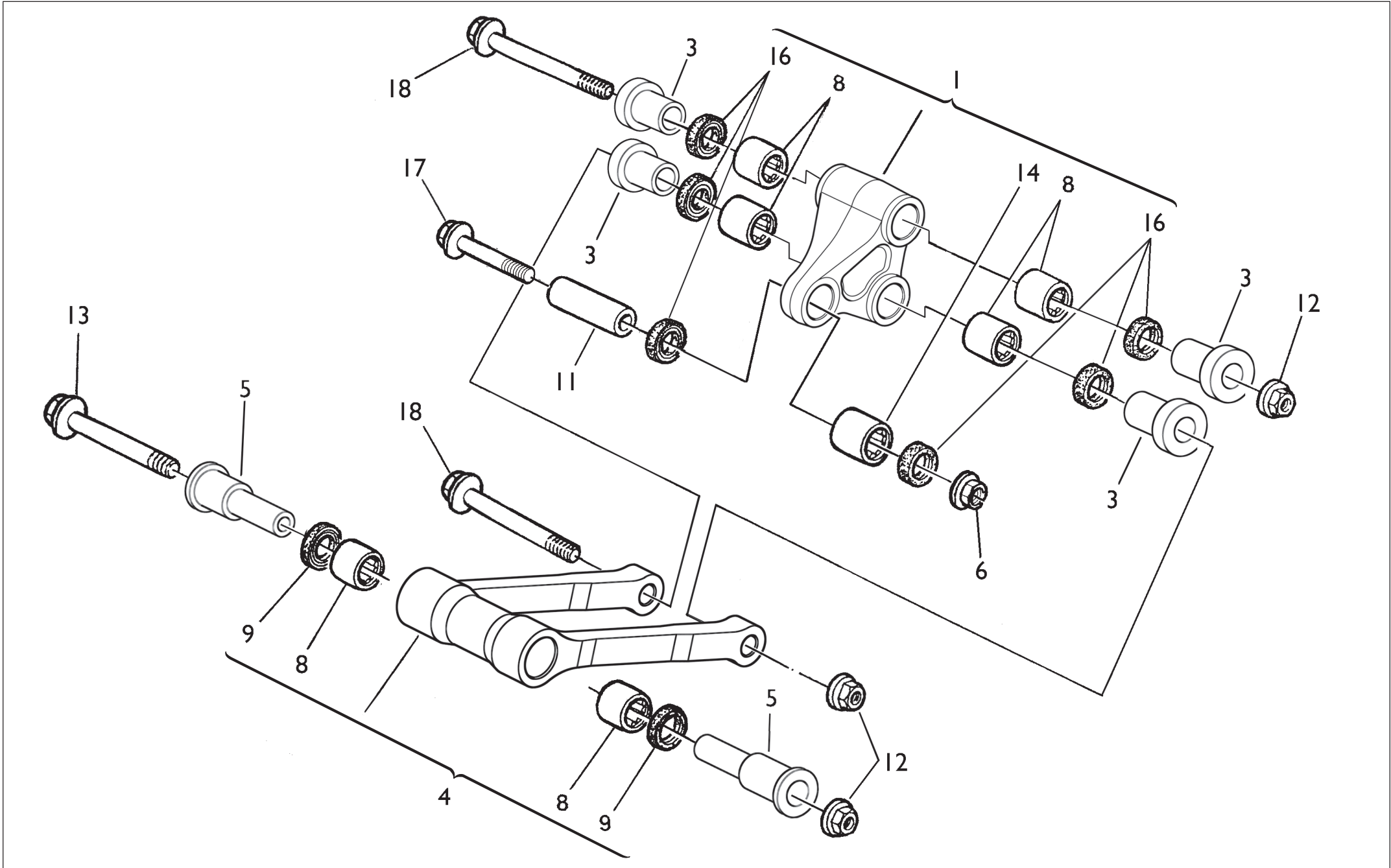

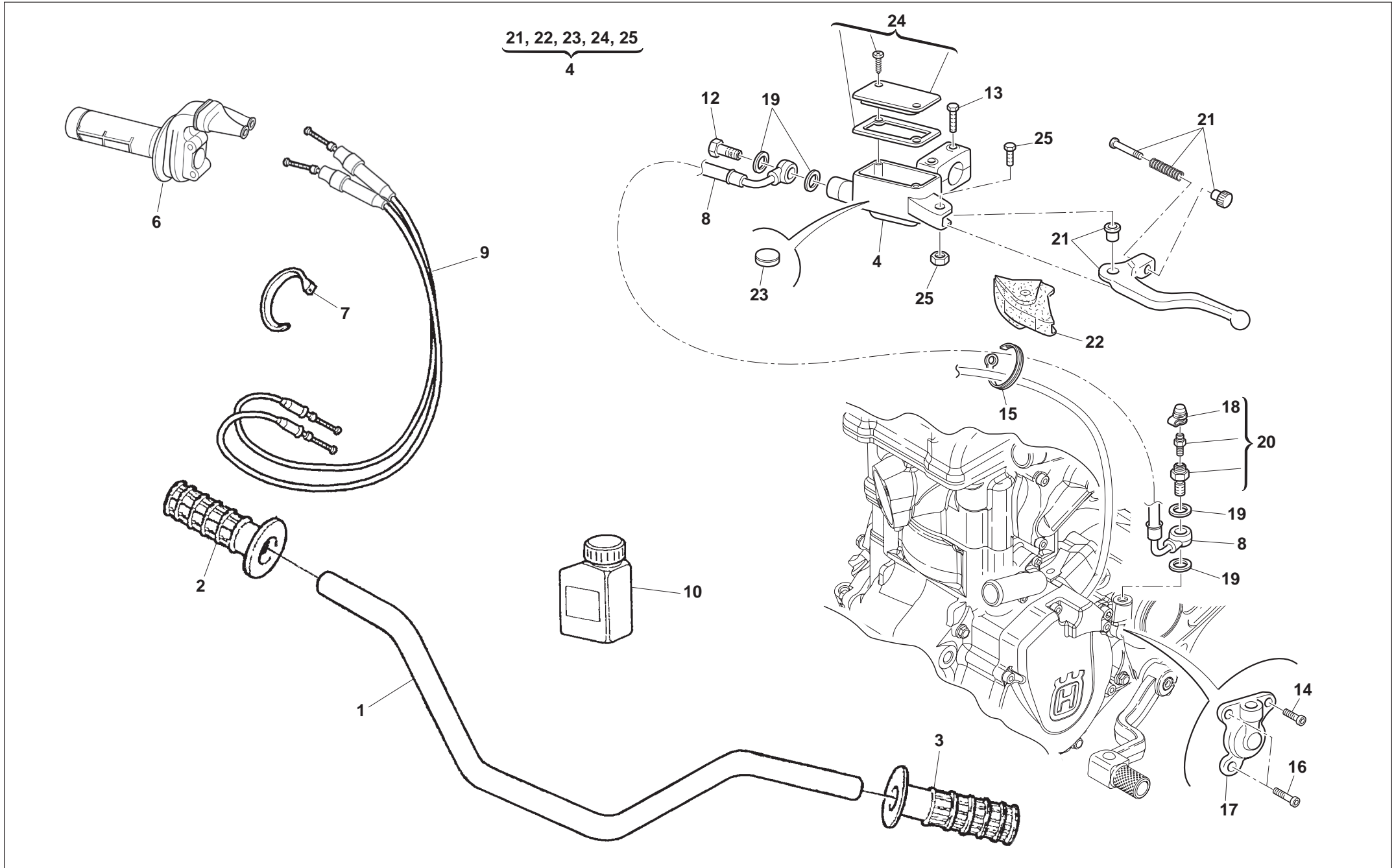

MANUBRIO E COMANDI - HANDLEBAR AND CONTROLS GUIDON ET COMMANDES - LENKER UND STEUERORGANE MANILLAR Y MANDOS

Note Notes Marke Notas	Pos. No. N. Index Pos.	N. Cod. CodeNo. Nr. Code Code Nr N. Cod.	Q.tà Qty Q.te M.ge C.ad	DENOMINAZIONE	NAME	DESIGNATION	BESHREIBUNG	DENOMINACION	Validità Validity Validité Gültig Validez
	1	80B0 A3612	1	Manubrio	Hanblebar	Guidon	Lenker	Manillar	
	2	8000 A6056	1	Manopola Dx.	R.H. grip	Poignée G.	Griff R.	Manopla der.	
	3	8000 A6057	1	Manopola Sx.	L.H. grip	Poignée G.	L. Griff	Manopla izrda.	
	4	8000 H0884	1	Ass. pompa comando frizione	Clutch control pump assy	Pompe comm. embrayage	Kupplungspumpe, Kpl.	Bomba mando embrague	
	6	8000 98209	1	Comando gas completo	Throttle control compl.	Commande gaz compl.	Gasgriff kpl.	Accionamiento acelerador compl.	
	7	8000 71578	2	Fascetta	Clamp	Collier	Schelle	Banda	
	8	8000 H0885	1	Tubo mandata olio	Pipe	Tuyau	Rohr	Tubo	
	9	8000 A4630	1	Trasmissione comando gas	Throttle wire	Fil comm. gaz	Gaszugkabel	Transmisión accionam. acelerador	
R	10	8000 97219	1	Olio frizione	Clutch oil	Huile embrayage	Kupplungsol	Aceite embrague	
	12	8000 57155	1	Vite	Screw	Vis	Schraube	Tornillo	
	13	8000 62728	1	Vite	Screw	Vis	Schraube	Tornillo	
	14	60N1 02505	1	Vite M6-L12	Screw M6-L12	Vis M6-L12	Schraube M6-L12	Tornillo M6-L12	
	15	8000 A1792	1	Fascetta	Clamp	Collier	Schelle	Banda	
	16	60N1 07335	2	Vite M6-L16	Screw M6-L16	Vis M6-L16	Schraube M6-L16	Tornillo M6-L16	
	17	8000 A7048	1	Cilindro com. frizione	Clutch control cylinder	Cylindre comm. embrayage	Kupplungszylinder	Cilindro mando embrague	
	18	8000 53259	1	Parapolvere	Boots	Para-poudr	Schutzhaube	Para-polvo	
	19	8000 21480	4	Rosetta	Washer	Rondelle	Scheibe	Arandela	
	20	8000 A3975	1	Bocchettone spurgo completo	Bleeding union pipe	Goulotte révision curage	Reinigungstutzen	Boca de purga	
	21	8000 H1982	1	Leva completa	Lever assy	Levier compl.	Hebel kpl.	Palanca compl.	
	22	8000 H1983	1	Cappuccio	Cap	Capuchon	Kappe	Capuchón	
	23	8000 79099	1	Antiemulsione	Antiemulsion	Antiemulsion	Emulsionwidriger	Antiemulsión	
	24	8000 H1984	1	Kit tappo	Plug kit	Bouchon kit	Verschluss Gruppe	Kit tapón	
	25	8000 H1985	1	Perno	Pin	Pivot	Bolzen	Perno	

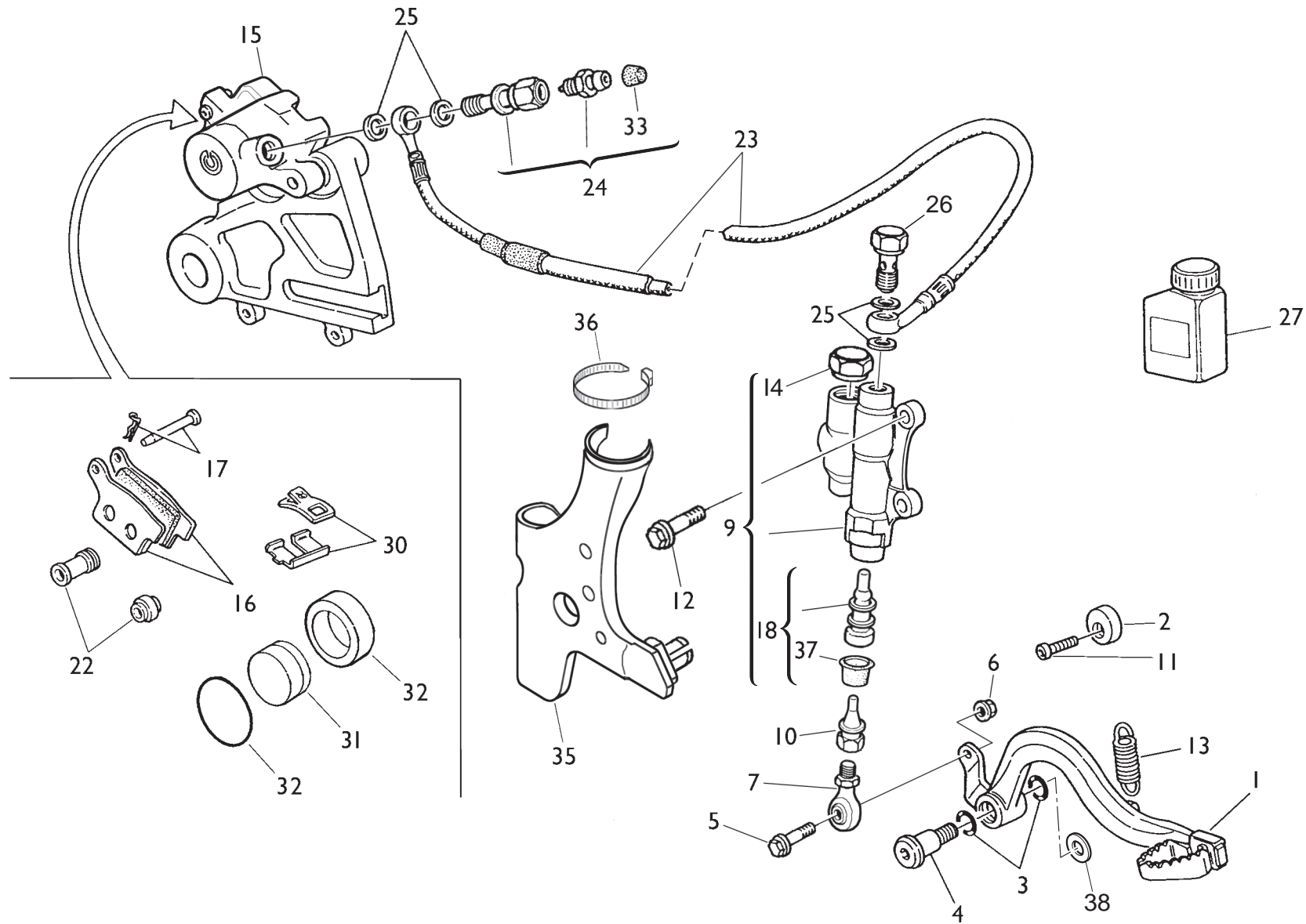

FRENO IDRAULICO POSTERIORE - REAR HYDRAULIC BRAKE
FREIN HYDRAULIQUE ARRIERE - HINTERBREMSE
FRENO HIDRAULICO TRASERO

Note Notes Marke Notas	Pos. No. Index Pos.	N. Cod. CodeNo. Nr. Code Code Nr N. Cod.	Q.tà Qty Q.te M.ge C.ad	DENOMINAZIONE	NAME	DESIGNATION	BESHREIBUNG	DENOMINACION	Validità Validity Validité Gültig Validez
	1	8000 A7634	1	Pedale comando freno	Brake control pedal	Pedal comm. frein	Bremspedal	Pedal accionamiento freno	
	2	8A00 69125	1	Camma	Cam	Came	Nocken	Exéntrico	
	3	8000 22551	2	Anello OR	O-Ring	Bague OR	O-Ring	Anillo OR	
	4	8000 55902	1	Vite	Screw	Vis	Schraube	Tornillo	
	5	8000 62727	1	Vite	Screw	Vis	Schraube	Tornillo	
	6	61N1 15062	1	Dado	Nut	Ecrou	Mutter	Tuerca	
	7	7640 10002	1	Snodo sferico Dx	Ball joint Right	Joint a rotule Droite	Kugelgelenk R.	Articulación esférica Derecha	
A	7	8A00 76055	1	Snodo sferico	Ball joint	Joint a rotule	Kugelgelenk	Articulación esférica	
	9	8000 A7633	1	Pompa comando freno	Brake pump assy	Pompe frein complet	Bremspumpe kl.	Bomba freno compl.	
	10	8000 A7635	1	Puntalino	Push rod	Embout	Stösselschaft	puntal	
	11	8000 55241	1	Vite	Screw	Vis	Schraube	Tornillo	
	12	8000 62726	2	Vite	Screw	Vis	Schraube	Tornillo	
	13	8000 55903	1	Molla	Spring	Ressort	Feder	Resorte	
	14	8000 A9447	1	Tappo	Plug	Bouchon	Verschluss	Tapón	
	15	8000 A4291	1	Pinza freno completa	Brake caliper assy	Pince de frein, compl.	Bremszange, Kpl.	Pinza freno compl.	
	16	8000 A2790	1	Coppia pastiglie	Pads pair	Paire plaquettes	Bremsbelagpaar	Pareja pastillas	
	17	8000 A2791	1	Perno	Pin	Pivot	Bolzen	Perno	
	18	8000 A9448	1	Flottante	Plunger	Piston	Kolben	Pistón	
	22	8000 79066	1	Cuffie	Boots	Poussiers	Haube	Gorro	
	23	8A00 B1162	1	Tubo freno posteriore	Rear brake tube	Tuyau du frein AR.	Hintere Bremsleitung	Tubo freno trasero	
	24	8000 A3975	1	Bocchettone completo	Pipe union assy	Goulotte compl.	Stutzen Kpl.	Boca compl.	
	25	8000 90485	4	Rosetta	Washer	Rondelle	Scheibe	Arandela	
	26	8000 57155	1	Vite	Screw	Vis	Schraube	Tornillo	
R	27	8000 97219	1	Olio freni	Brake oil	Huile de frein	BremsÖl	Aceite freno	
	30	8000 A2792	1	Molla-lamierino	Spring-steel clip	Ressort	Feder	Rresorte	
	31	8000 A2793	1	Pistone	Piston	Piston	Kolben	Pistón	
	32	8000 A2794	1	Kit guarnizioni pistone	Kit gasket piston	Kit garniture piston	Kit Kolbendichtung	Kit juntas pistón	
	33	8000 53259	1	Parapolvere	Boots	Para-poudre	Schutzhaube	Para-polvo	
	35	80A0 B0246	1	Protezione telaio Dx	R.H. frame guard	Protection chassis D.	Rahmenschutz Rechts	Protección bastidor derecha	
	36	8000 56444	1	Fascetta (L=188mm)	Clamp (L=188mm)	Collier (L=188mm)	Schelle (L=188mm)	Banda (L=188mm)	
	37	8000 A9449	1	Cuffia	Hood	Coiffe	Haube	Gorro	
	38	8000 H1412	1	Rosetta	Washer	Rondelle	Scheibe	Arandela	

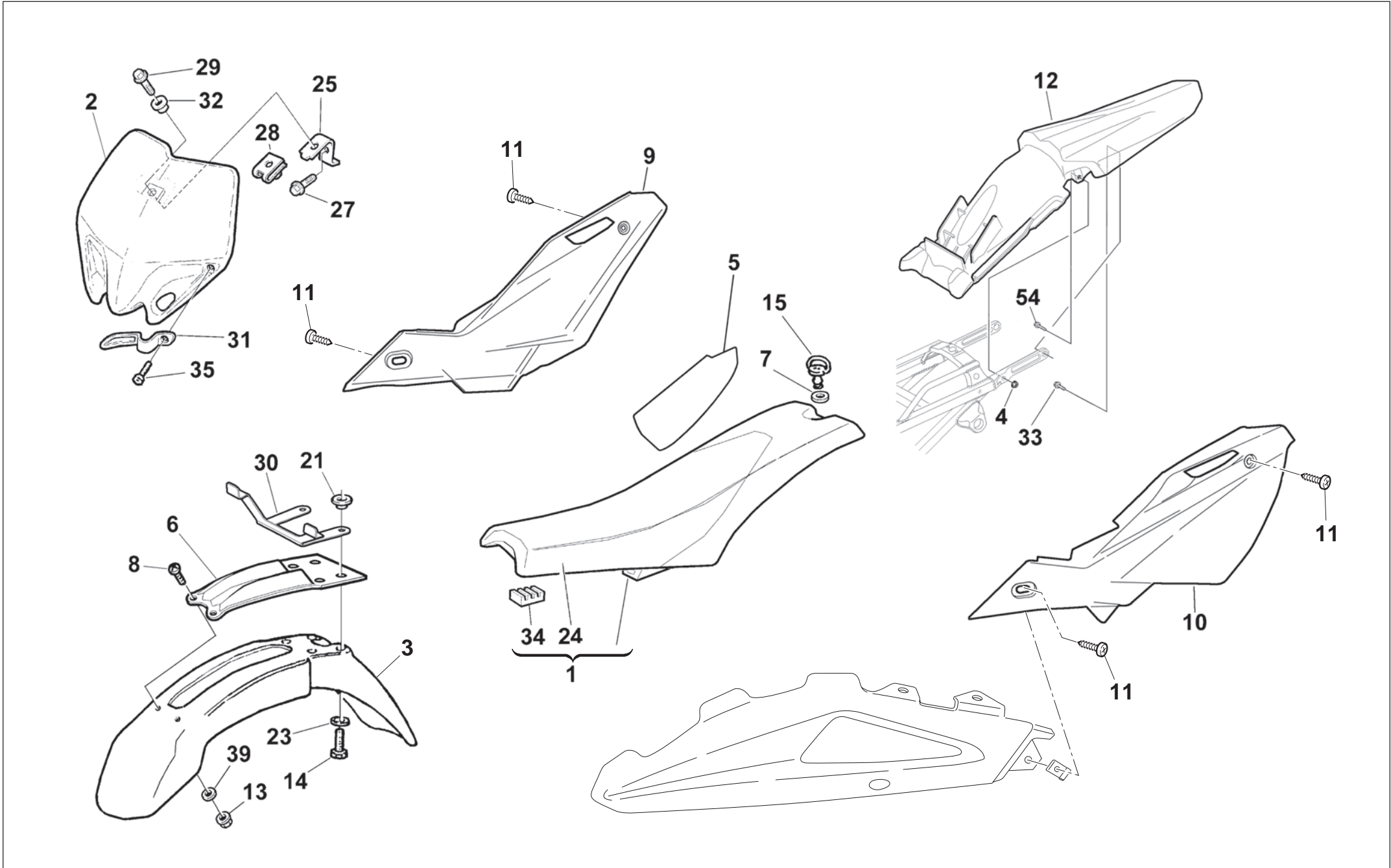

Note Notes Marka Notas	Pos. No. Index Pos.	N. Cod. CodeNo. Nr. Code Code Nr N. Cod.	Q.tà Qty Q.te M.ge C.ad	DENOMINAZIONE	NAME	DESIGNATION	BESHREIBUNG	DENOMINACION	Validità Validity Validité Gültig Validez
	1	8000 B0170	1	Sella (codice colore G) Nero	Seat (color code G) Black	Siège (code couleur G) Noir	Sattel (Code Farbe G) Schwarz	Sillín (còdigo colòr G) Negro	
	2	80C0 A4216	1	Portanumero (codice colore G) Bianco	Front number holder (color code G) White	Portenumero (code couleur G) Blanc	Nummerträger (Code Farbe G) Weiss	Portanumero (còdigo colòr G) Blanco	
	3	80C0 H0878	1	Parafango ant. (codice colore G) Bianco	Front mudguard (color code G) White	Garde-boue avant (code couleur G) Blanc	Vord. Kotfluegel (Code Farbe G) Weiss	Guarda-barros del. (còdigo colòr G) Blanco	
	4	8000 61313	2	Dado	Nut	Ecrou	Mutter	Tuerca	
	5	8000 B0167	1	Protezione paracalore	Heat guard	Protection pare-chaueur	Hizeschutz	Protección paracalor	
	6	80A0 A4198	1	Rinforzo per parafango	Fender holder	Soutie pour garde-boue	Kotfluegel support	Soporte por guardabarros del.	
	7	8000 69149	1	Rosetta elastica	Washer	Rondelle	Scheibe	Arandela	
	8	Z000 65535	2	Vite	Screw	Vis	Schraube	Tornillo	
	9	80C0 B0164	1	Pannello DX (codice colore G) Bianco	R.H. panel (color code G) White	Panneau, D. (code couleur G) Blanc	Streifen. R. (Code Farbe G) Weiss	Panel Der. (còdigo colòr G) Blanco	
	10	80C0 B0163	1	Pannello SX (codice colore G) Bianco	L.H. panel (color code G) White	Panneau, G. (code couleur G) Blanc	Streifen. L. (Code Farbe G) Weiss	Panel Izq. (còdigo colòr G) Blanco	
	11	8B00 A8421	4	Vite M5-L16	Screw M5-L16	Vis M5-L16	Schraube M5-L16	Tornillo M5-L16	
	12	80C0 H0705	1	Parafango post. (codice colore G) Bianco	Rear mudguard (color code G) White	Garde-boue arriere (code couleur G) Blanc	Hint. Kotfluegel (Code Farbe G) Weiss	Guarda-barros tras. (còdigo colòr G) Blanco	
	13	Z000 61355	2	Dado	Nut	Ecrou	Mutter	Tuerca	
	14	8000 62729	4	Vite M6-L25	Screw M6-L25	Vis M6-L25	Schraube M6-L25	Tornillo M6-L25	
	15	8000 69148	1	Perno	Pin	Pivot	Bolzen	Perno	
	21	8C00 69429	4	Bussola	Bushing	Douille	Buchse	Manguito	
	23	8000 48814	4	Rosetta	Washer	Rondelle	Scheibe	Arandela	
	24	8000 B0171	1	Rivestimento sella (cod. colore G) Nero	Saddle covering (color code G) Black	Revetement selle (code couleur G) Noir	Sattelverkleidung (code Farbe G) Schwarz	Revestimiento sillin (còdigo colòr G) Negro	
	25	8000 A4609	1	Piastrina	Plate	Plaquette	Plättchen	Placa	
	27	8E00 67997	1	Vite M5-L10	Screw M5-L10	Vis M5-L10	Schraube M5-L10	Tornillo M5-L10	
	28	8000 46893	1	Dado	Nut	Ecrou	Mutter	Tuerca	
	29	8000 62726	1	Vite M6-L14	Screw M6-L14	Vis M6-L14	Schraube M6-L14	Tornillo M6-L14	
	30	8000 A6644	1	Attacco portanumero	Spacer	Entretoise	Distanzstück	Separador	
	31	80A0 A4610	1	Guidafilo	Cable guide	Passe-cable	Kabelführung	Prensa-cable	
	32	8000 69429	1	Bussola	Bushing	Douille	Buchse	Manguito	
	33	8000 A8423	2	Vite M6-L8	Screw M6-L8	Vis M6-L8	Schraube M6-L8	Tornillo M6-L8	
	34	8661 0191A	2	Tampone appoggio sella	Pad	Tampon	Stopflen	Tampòn	
	35	8000 62728	1	Vite M6-L20	Screw M6-L20	Vis M6-L20	Schraube M6-L20	Tornillo M6-L20	
	39	62N1 15548	2	Rosetta	Washer	Rondelle	Scheibe	Arandela	
	54	8B00 A8423	2	Vite flangiata	Flange bolt	Boulon de bride	Flanschschraube	Perno de reborde	

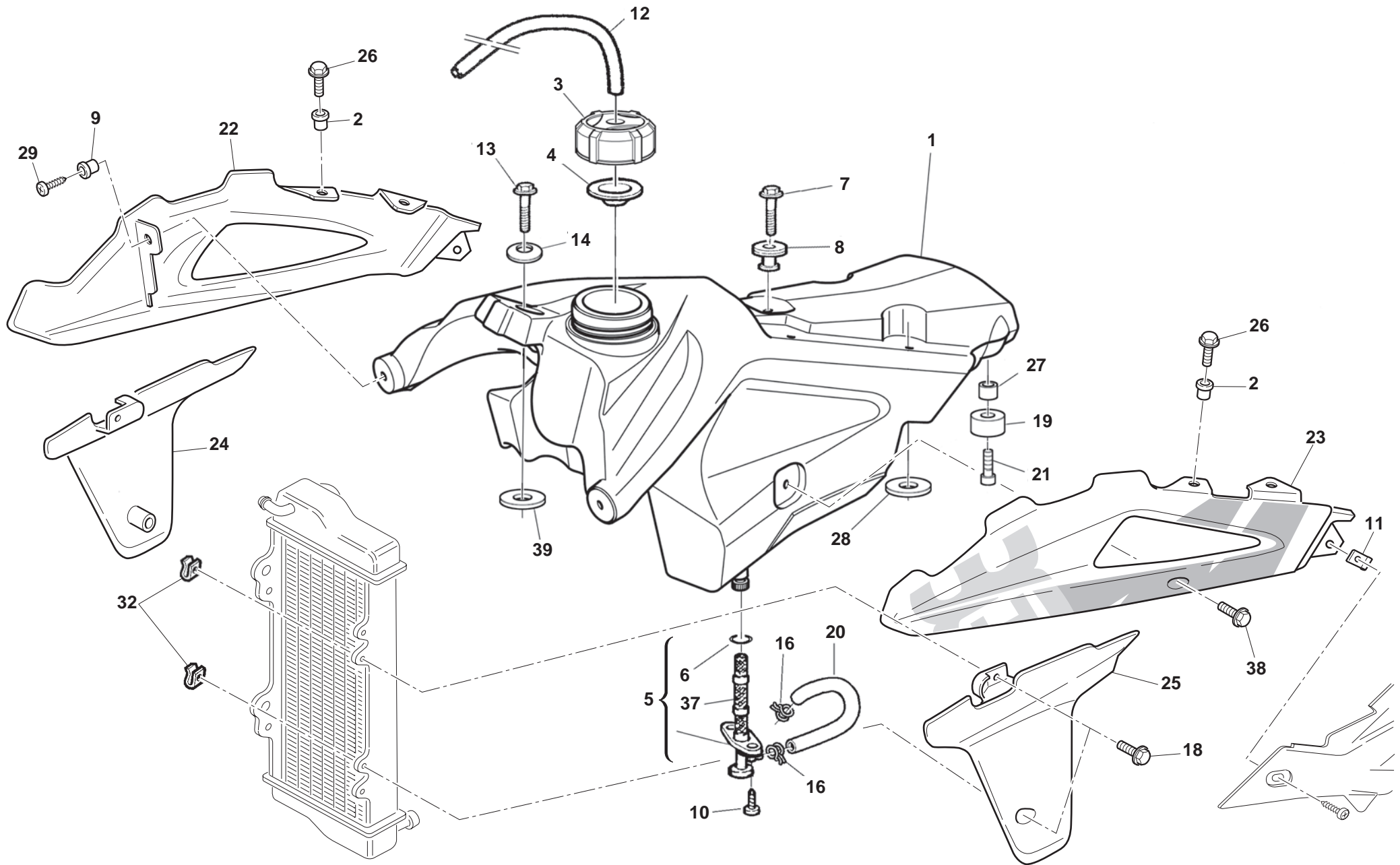

Note Notes Marke Notas	Pos. No. Index Pos.	N. Cod. CodeNo. Nr. Code Code Nr N. Cod.	Q.tà Qty Q.te M.ge C.ad	DENOMINAZIONE	NAME	DESIGNATION	BESHREIBUNG	DENOMINACION	Validità Validity Validité Gültig Validez
	1	8000 H0056	1	Serbatoio carburante	Fuel tank	Réservoir essence	Kraftstoffbehälter	Depósito	
	2	8000 69282	4	Bussola	Bushing	Douille	Buchse	Manguito	
	3	8000 B1057	1	Tappo serbatoio	Tank cap	Bouchon reservoir	Behälterstöpsel	Tapón depósito	
	4	8000 A4562	1	Guarnizione	Gasket	Garnitue	Dichtung	Junta	
	5	8000 67440	1	Rubinetto benzina	Fuel cock	Robinet de combustible	Kraftstoffhahn	Llave de paso gasolina	
	6	8000 A8278	1	Anello OR	O-Ring	Bague OR	O-Ring	Anillo OR	
	7	60N1 04134	1	Vite M6-L20	Screw M6-L20	Vis M6-L20	Schraube M6-L20	Tornillo M6-L20	
	8	8000 66238	1	Distanziale	Spacer	Entretoise	Distanzstück	Separador	
	9	8000 45495	2	Bussola	Bushing	Douille	Buchse	Manguito	
	10	8000 37745	2	Vite	Screw	Vis	Schraube	Tornillo	
	11	8000 55134	2	Dado M5	Nut M5	Ecrou M5	Mutter M5	Tuerca M5	
	12	8T00 68873	1	Condotto sfiato (L=300 mm)	Breather line (L=300 mm)	Conduite purge (L=300 mm)	Entlüftungsleitung (L=300 mm)	Tuberia purga de aire (L=300 mm)	
	13	60N4 07335	1	Vite M6-L16	Screw M6-L16	Vis M6-L16	Schraube M6-L16	Tornillo M6-L16	
	14	8000 A5678	1	Rosetta	Washer	Rondelle	Scheibe	Arandela	
	16	80A0 42349	2	Fascetta	Clamp	Collier	Schelle	Banda	
	18	8A00 A8423	4	Vite M6-L12	Screw M6-L12	Vis M6-L12	Schraube M6-L12	Tornillo M6-L12	
	19	8000 B0647	2	Tampone	Pad	Tampon	Stopfen	Tampón	
	20	8F00 94010	1	Condotto benzina (L=330mm)	Pipe (L=330mm)	Tuyau (L=330mm)	Rohr (L=330mm)	Tubo (L=330mm)	
	21	8000 37745	2	Vite	Screw	Vis	Schraube	Tornillo	
	22	8000 H0474	1	Convogliatore Dx con adesivo	Right side panel with adhesive	Flanc Droite avec adhésif	Flanke R. mit klebe	Lateral Derecha con pegatina	
	23	8000H0473	1	Convogliatore Sx con adesivo	Left side panel with adhesive	Flanc Gouche avec adhésif	Flanke L. mit klebe	Lateral Izquierda con pegatina	
	24	8000 H0256	1	Protezione Dx	R.H. protection	Protection D.	Schutz Rechte	Protección der.	
	25	8000 H0255	1	Protezione Sx	L.H. protection	Protection G.	Schutz Linke	Protección izquierda	
	26	8000 67997	4	Vite M5-L12	Screw M5-L12	Vis M5-L12	Schraube M5-L12	Tornillo M5-L12	
	27	8B00 A0680	2	Distanziale	Spacer	Entretoise	Distanzstück	Separador	
	28	8A00 61362	2	Rosetta	Washer	Rondelle	Scheibe	Arandela	
	29	8000 37745	2	Vite	Screw	Vis	Schraube	Tornillo	
	32	8000 60873	4	Dado a graffetta	Nut	Ecrou	Mutter	Tuerca	
	37	8000 67700	1	Filtro	Filter	Filtre	Filter	Filtro	
	38	8000 A8421	2	Vite M5-L8	Screw M5-L8	Vis M5-L8	Schraube M5-L8	Tornillo M5-L8	
	39	8000 61362	1	Rosetta					

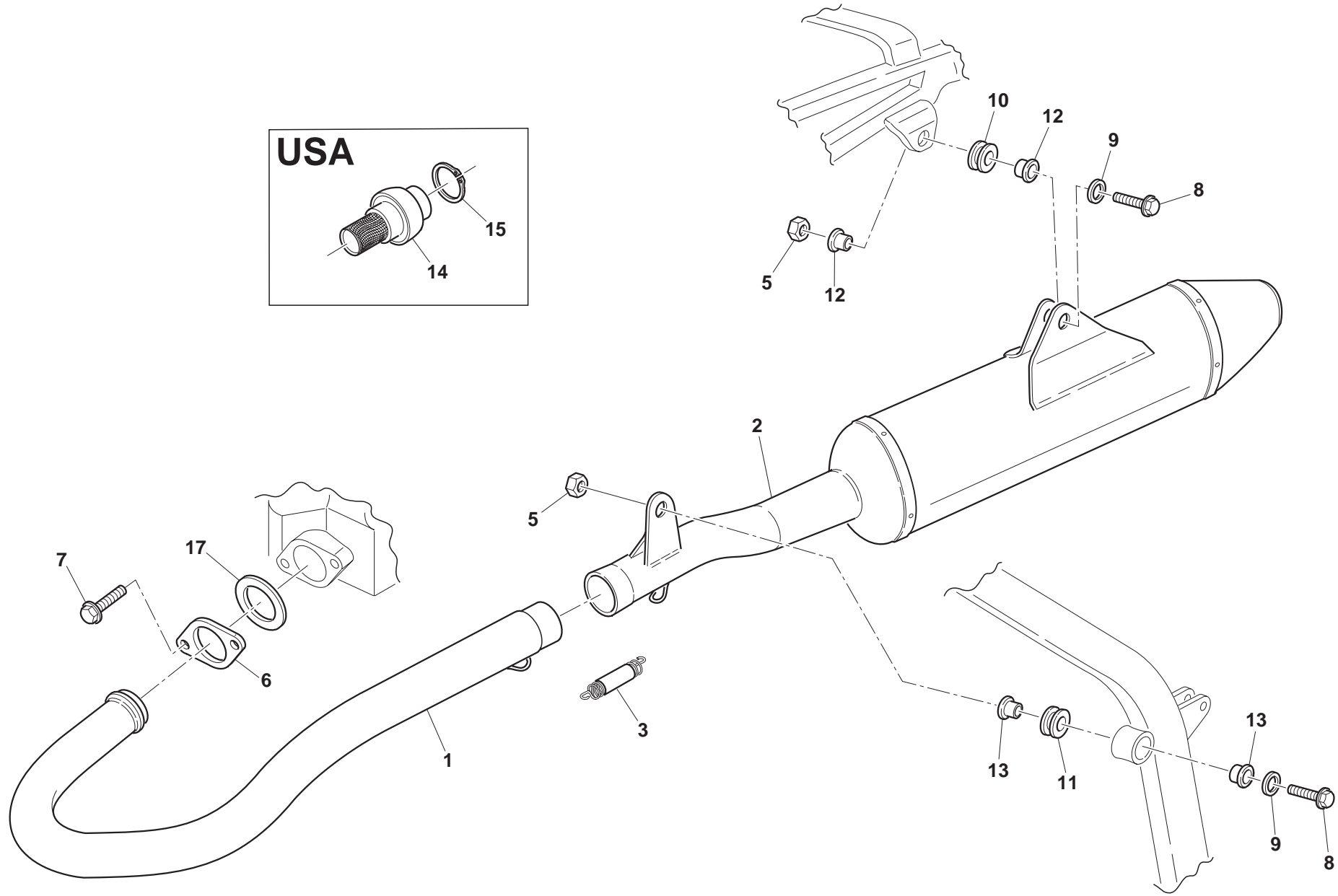
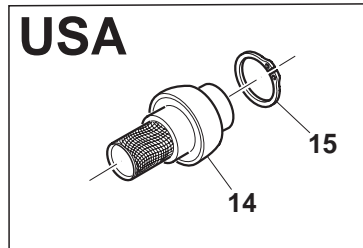



TC 250/2009

SCARICO - EXHAUST SYSTEM TUYAU D'ECHAPPEMENT - AUSPUFFROHR TUBO DE ESCAPE

TAVOLA
DRAWING
TABLE
BLD
TABLA

29

Note Notes Mark Notas	Pos. No. N. Index Pos.	N. Cod. CodeNo. Nr. Code Code Nr N. Cod.	Q.tà Qty Q.te M.ge C.ad	DENOMINAZIONE	NAME	DESIGNATION	BESHREIBUNG	DENOMINACION	Validità Validity Validité Gültig Validez
	1	8000 H1421	1	Tubo di scarico	Exhaust pipe	Tuyau d'échapp.	Auspuffrohr	Tubo de escape	
	2	8000 H1422	1	Silenziatore	Silencer	Silencieux	Schalldämpfer	Silenciador	
	2	8000 H1423	1	Silenziatore (USA)	Silencer (USA)	Silencieux (USA)	Schalldämpfer (USA)	Silenciador (USA)	
	3	8000 A1239	1	Molla	Spring	Ressort	Feder	Resorte	
	5	8000 44240	2	Dado M6	Nut M6	Ecrou M6	Mutter M6	Tuerca M6	
	6	8000 H1074	1	Flangia	Flange	Bride	Flansch	Brida	
	7	8000 69056	2	Vite	Screw	Vis	Schraube	Tornillo	
	8	8A00 67545	2	Vite M6-L35	Screw M6-L35	Vis M6-L35	Schraube M6-L35	Tornillo M6-L35	
	9	8000 22271	2	Rosetta	Washer	Rondelle	Scheibe	Arandela	
	10	8000 B0263	2	Distanziale	Spacer	Entretoise	Distanzstück	Separador	
	11	8000 H0064	1	Gommino	Rubber pad	Pièce caoutchouc	Gummistück	Junta de goma	
	12	8000 A7729	2	Diastanziale	Spacer	Entretoise	Distanzstück	Separador	
	13	8000 H0084	1	Gommino	Rubber pad	Pièce caoutchouc	Gummistück	Junta de goma	
	14	8000 B1307	1	Spark arrester (USA-CDN)	Spark arrester (USA-CDN)	Spark arrester (USA-CDN)	Spark arrester (USA-CDN)	Spark arrester (USA-CDN)	
	15	8000 B1305	1	Anello elastico	Split ring	Anneau ressort	Sprengring	Anillo elástico	
	17	8000 H0015	1	Guarnizione	Gasket	Garnitue	Dichtung	Junta	

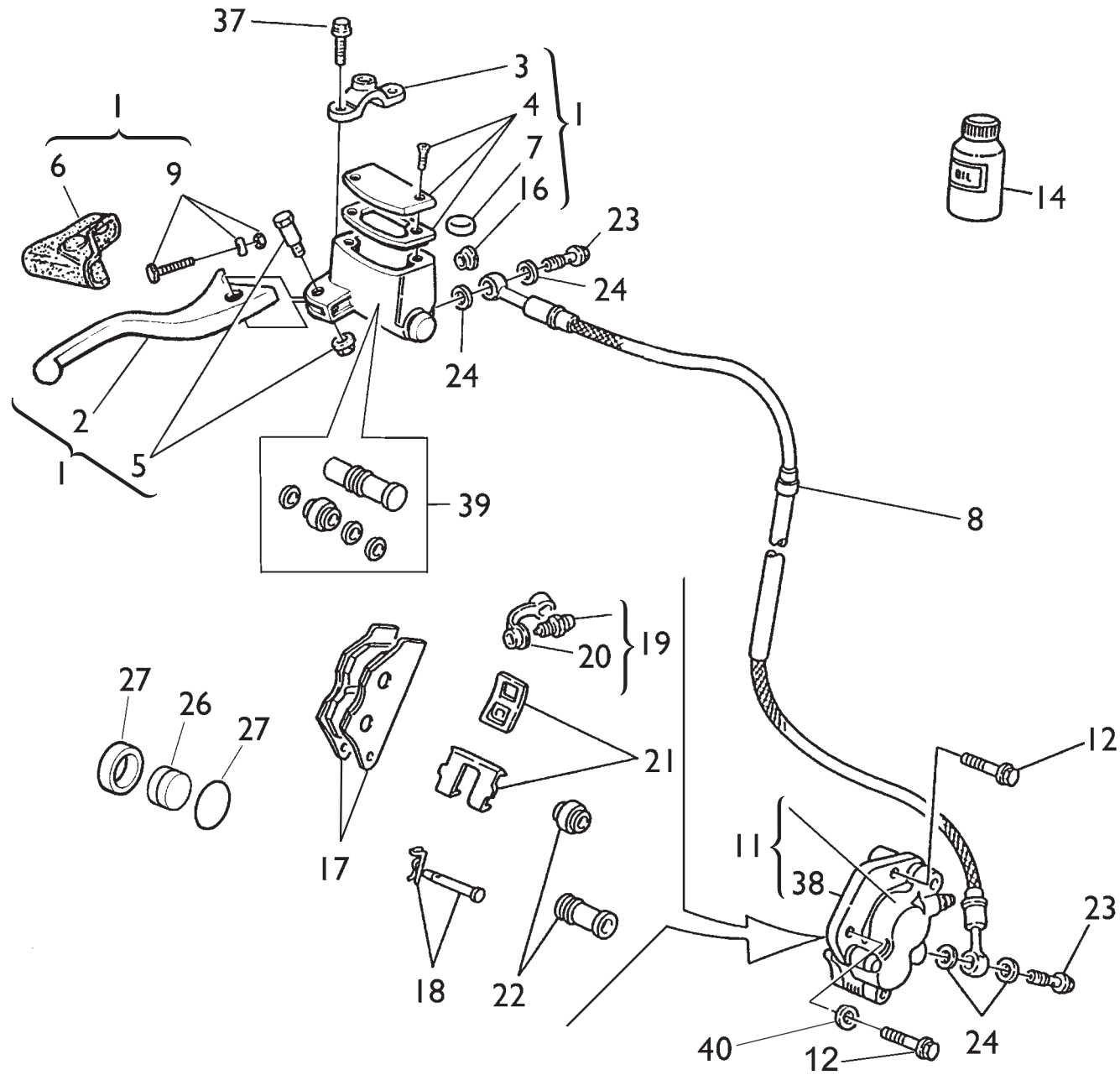

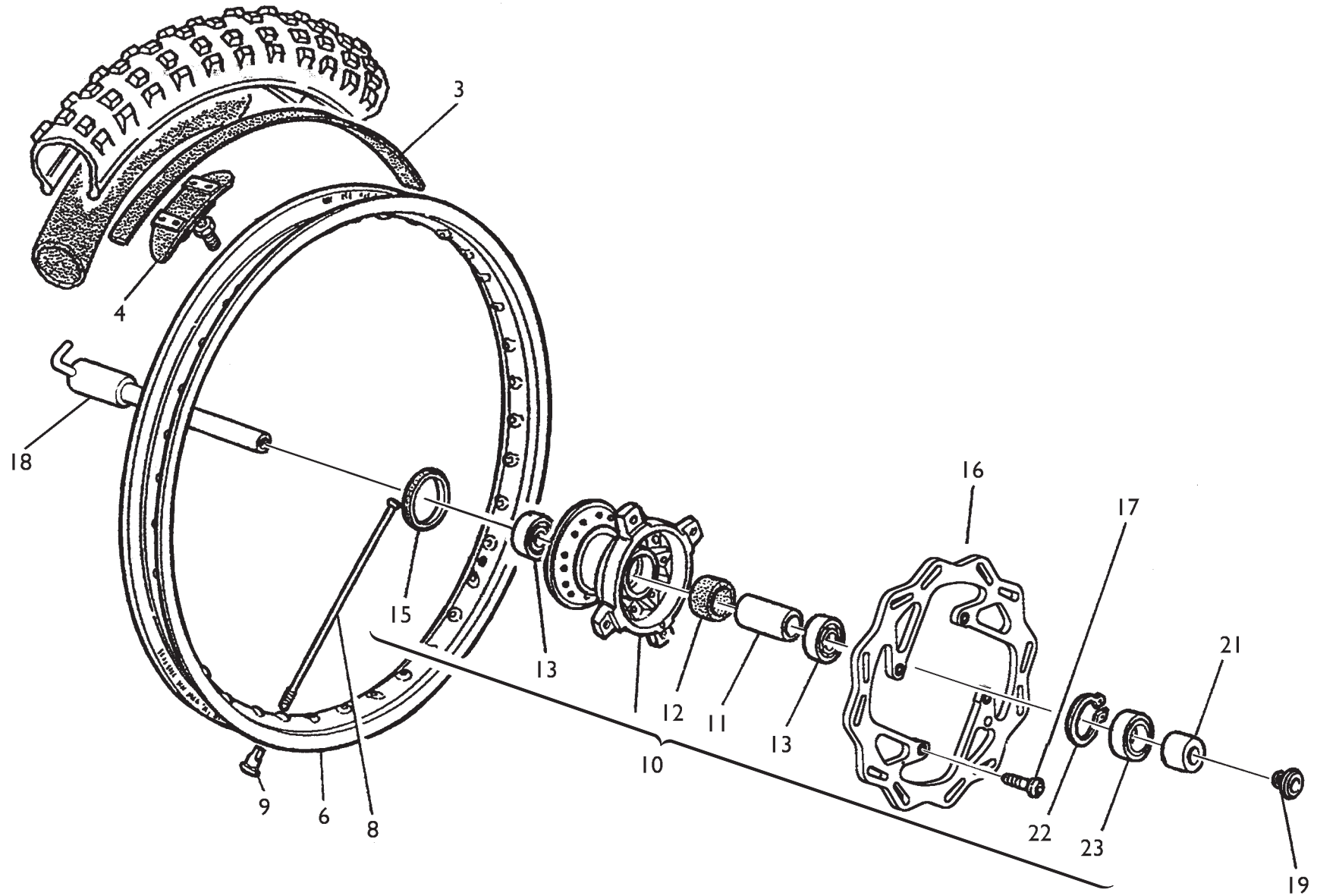

RUOTA ANTERIORE - FRONT WHEEL
ROUE AV. - VORTERRAD
RUEDA DELANTERA

Note Notes Marke Notas	Pos. No. N. Index Pos.	N. Cod. Code No. Nr. Code Code Nr N. Cod.	Q.tà Qty Q.te M.ge C.ad	DENOMINAZIONE	NAME	DESIGNATION	BESHREIBUNG	DENOMINACION	Validità Validity Validité Gültig Validez
	3	8000 13346	1	Fascia copriraggi	Rim strip	Bande	Band	Banda	
	4	8000 49036	1	Staffa fermacopertone	Bracket	Etrier	Buegel	Brida	
	6	8AB0 53504	1	Cerchio (1,6"x21")	Rim (1,6"x21")	Jante (1,6"x21")	Felge (1,6"x21")	Llanta (1,6"x21")	
	8	8000 A6207	36	Raggio ALPINA	Spoke ALPINA	Bras ALPINA	Speiche ALPINA	Radio ALPINA	
	8	8000 A0080	36	Raggio DID	Spoke DID	Bras DID	Speiche DID	Radio DID	
	9	8000 A6208	36	Nipplo ALPINA	Nipple ALPINA	Nipple ALPINA	Nippel ALPINA	Nipple ALPINA	
	9	8000 A0081	36	Nipplo DID	Nipple DID	Nipple DID	Nippel DID	Nipple DID	
	10	8000 96838	1	Mozzo completo	Hub assy	Moyeau compl.	Radnabe, Kpl.	Cubo compl.	
	11	8000 96928	1	Distanziale	Spacer	Entretoise	Distanzstück	Separador	
	12	8000 92797	1	Portadistanziale	Spacer holder	Porte-entretoise	Abstandstückhalter	Porta-distancial	
	13	8000 84938	2	Cuscinetto a sfere (ø25xø42x9 mm)	Ball bearing (ø25xø42x9 mm)	Roulement à billes (ø25xø42x9 mm)	Kugellager (ø25xø42x9 mm)	Cojinete de bolas (ø25xø42x9 mm)	
	15	8A00 92986	1	Anello di tenuta (ø28xø50x5 mm)	Seal ring (ø28xø50x5 mm)	Bague de retenue (ø28xø50x5 mm)	Dichtring (ø28xø50x5 mm)	Anillo de retenció (ø28xø50x5 mm)	
	16	8000 H0192	1	Disco freno (ø260 mm)	Brake disc (ø260 mm)	Disque frein (ø260 mm)	Bremsscheibe (ø260 mm)	Disco freno (ø260 mm)	
	17	8A00 55241	4	Vite M6-L14	Screw M6-L14	Vis M6-L14	Schraube M6-L14	Tornillo M6-L14	
	18	8B00 96932	1	Perno ruota	Pin	Pivot	Bolzen	Perno rueda	
	19	8000 96933	1	Vite	Screw	Vis	Schraube	Tornillo	
	21	8A00 96930	1	Distanziale	Spacer	Entretoise	Distanzstück	Separador	
	22	66N0 21270	1	Anello SEEGER	Seeger ring	Bague seeger	Seegerring	Anillo Seeger	
	23	8000 22966	1	Anello di tenuta (ø32xø42x7 mm)	Seal ring (ø32xø42x7 mm)	Bague de retenue (ø32xø42x7 mm)	Dichtring (ø32xø42x7 mm)	Anillo de retención (ø32xø42x7 mm)	

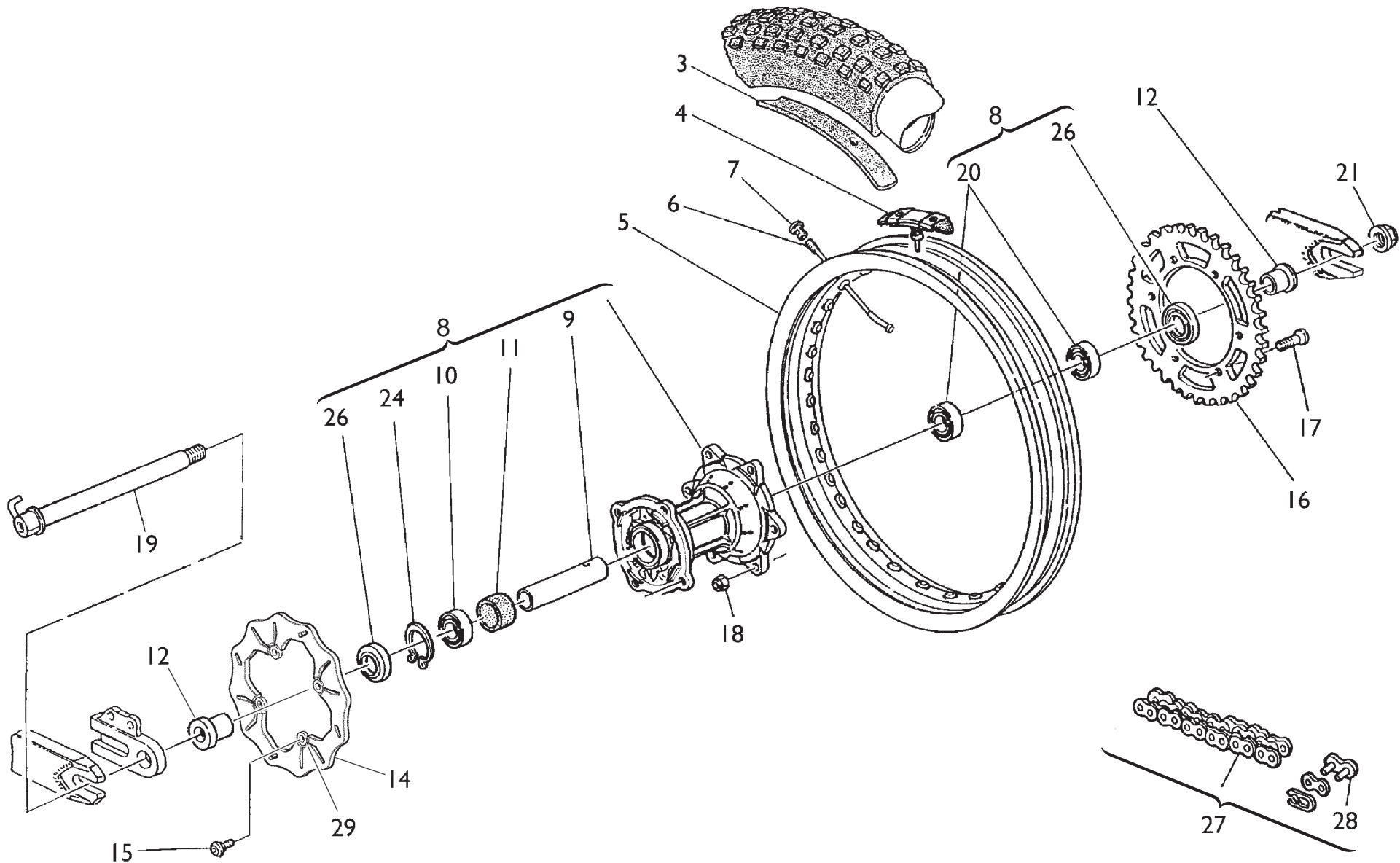

Note Notes Marke Notas	Pos. No. Index Pos.	N. Cod. CodeNo. Nr. Code Code Nr N. Cod.	Q.tà Qty Q.te M.ge C.ad	DENOMINAZIONE	NAME	DESIGNATION	BESHREIBUNG	DENOMINACION	Validità Validity Validité Gültig Validez
	3	8000 10777	1	Fascia copriraggi	Rim strip	Bande	Band	Banda	
	4	8000 49035	1	Staffa fermacopertone	Bracket	Etrier	Buegel	Brida	
	5	8AA0 58930	1	Cerchio (1,85" x 19")	Rim (1,85" x 19")	Jante (1,85" x 19")	Felge (1,85" x 19")	Llanta (1,85" x 19")	
	6	8A00 A0085	36	Raggio DID	Spoke DID	Bras DID	Speiche DID	Radio DID	
	6	8A00 A6206	18	Raggio ALPINA lato disco	Spoke ALPINA brake side	Bras ALPINA côte frein	Speiche ALPINA Bremsseite	Radio ALPINA lado disco	
	6	8C00 A6206	18	Raggio ALPINA lato corona	Spoke ALPINA ring gear side	Bras ALPINA côte couronne	Speiche ALPINA Kranzseite	Radio ALPINA lado corona	
	7	8000 A0086	36	Nipplo DID	Nipple DID	Nipple DID	Nippel DID	Nipple DID	
	7	8000 A6209	36	Nipplo ALPINA	Nipple ALPINA	Nipple ALPINA	Nippel ALPINA	Nipple ALPINA	
	8	8A00 96937	1	Mozzo completo	Hub assy	Moyeau compl.	Radnabe, Kpl.	Cubo compl.	
	9	8000 92414	1	Distanziale	Spacer	Entretoise	Distanzstück	Separador	
	10	8B00 26846	1	Cuscinetto (ø25xø47x16 mm)	Bearing (ø25xø47x16 mm)	Roulement (ø25xø47x16 mm)	Kugellager (ø25xø47x16 mm)	Cojinete (ø25xø47x16 mm)	
	11	8000 92797	1	Portadistanziale	Spacer holder	Porte-entretoise	Abstandstuckhalter	Porta-distancial	
	12	8000 96938	2	Distanziale	Spacer	Entretoise	Distanzstück	Separador	
	14	8000 H0195	1	Disco freno (ø240 mm)	Brake disc (ø240 mm)	Disque frein (ø240 mm)	Bremsscheibe (ø240 mm)	Disco freno (ø240 mm)	
	15	8000 62726	4	Vite	Screw	Vis	Schraube	Tornillo	
S	16	8D00 96837	1	Corona (Z= 50)	Ring gear (Z= 50)	Couronne (Z= 50)	Kranz (Z= 50)	Corona (Z= 50)	
R	16	8F00 96837	1	Corona (Z= 52)	Ring gear (Z= 52)	Couronne (Z= 52)	Kranz (Z= 52)	Corona (Z= 52)	
R	16	8C00 96837	1	Corona (Z= 49)	Ring gear (Z= 49)	Couronne (Z= 49)	Kranz (Z= 49)	Corona (Z= 49)	
	17	8000 H0158	6	Vite	Screw	Vis	Schraube	Tornillo	
	18	8000 43928	6	Dado	Nut	Ecrou	Mutter	Tuerca	
	19	8000 96940	1	Perno	Pin	Pivot	Bolzen	Perno	
	20	8A00 26846	2	Cuscinetto (ø25xø47x12 mm)	Bearing (ø25xø47x12 mm)	Roulement (ø25xø47x12 mm)	Kugellager (ø25xø47x12 mm)	Cojinete (ø25xø47x12 mm)	
	21	8000 93072	1	Dado	Nut	Ecrou	Mutter	Tuerca	
	24	66N0 21272	1	Anello seeger	Seeger ring	Bague seeger	Seegerring	Anillo seeger	
	26	8000 89572	2	Anello di tenuta Ø32xø47x7	Seal ring Ø32xø47x7	Bague de retenuta Ø32xø47x7	Dichtring Ø32xø47x7	Anillo de retención Ø32xø47x7	
A*	27	8E00 A9226	1	Catena (112 maglie) DID 5/8"x1/4"	Chain (112 maglie)DID 5/8"x1/4"	Chaîne (112 maglie) DID 5/8"x1/4"	Kette (112 maglie)DID 5/8"x1/4"	Cadena (112 maglie) DID 5/8"x1/4"	
A	27	8A00 56768	1	Catena Regina (112 maglie) 5/8"x1/4"	Chain Regina (112 maglie) 5/8"x1/4"	Chaîne Regina (112 maglie) 5/8"x1/4"	Kette Regina (112 maglie) 5/8"x1/4"	Cadena Regina (112 maglie) 5/8"x1/4"	
A°	27	8E00 79785	1	Catena (112 maglie) DID 5/8"x1/4"	Chain (112 maglie)DID 5/8"x1/4"	Chaîne (112 maglie) DID 5/8"x1/4"	Kette (112 maglie)DID 5/8"x1/4"	Cadena (112 maglie) DID 5/8"x1/4"	
A	28	8000 56767	1	Giunto Regina	Coupling Regina	Joint Regina	Kupplung Regina	Junta Regina	
A*	28	8000 A9227	1	Giunto DID	Coupling DID	Joint DID	Kupplung DID	Junta DID	
A°	28	8000 79790	1	Giunto DID	Coupling DID	Joint DID	Kupplung DID	Junta DID	
	29	8000 A0693	4	Bussola	Bushing	Douille	Bouchse	Manguito	

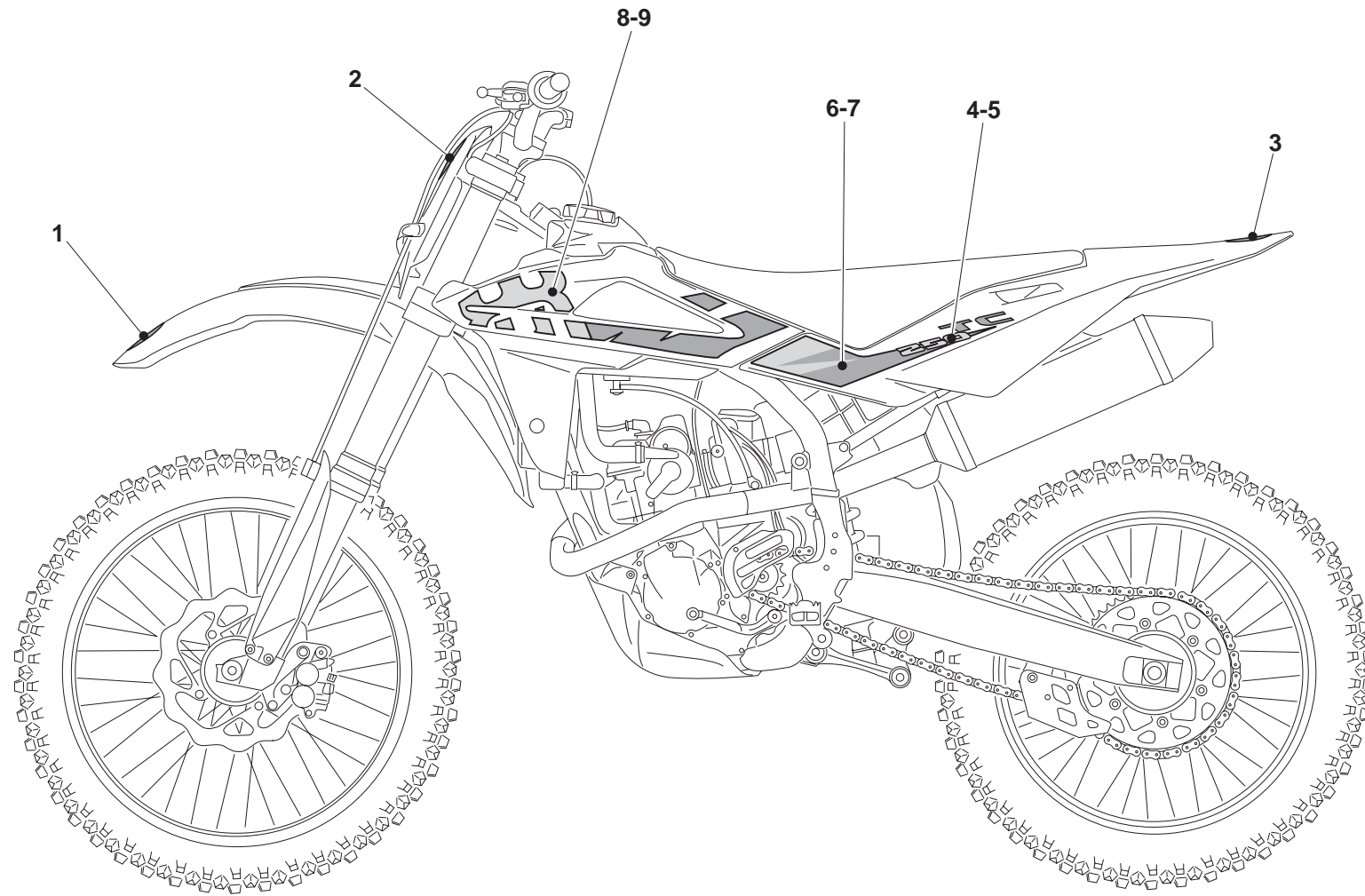

DISEGNO DRAWING DESSIN ZEICHNUNG DIBUJO	TAVOLA DRAWING TABLE BILD TABLA	INDEX NO. POS. N. INDICE	DISEGNO DRAWING DESSIN ZEICHNUNG DIBUJO	TAVOLA DRAWING TABLE BILD TABLA	INDEX NO. POS. N. INDICE	DISEGNO DRAWING DESSIN ZEICHNUNG DIBUJO	TAVOLA DRAWING TABLE BILD TABLA	INDEX NO. POS. N. INDICE	DISEGNO DRAWING DESSIN ZEICHNUNG DIBUJO	TAVOLA DRAWING TABLE BILD TABLA	INDEX NO. POS. N. INDICE	DISEGNO DRAWING DESSIN ZEICHNUNG DIBUJO	TAVOLA DRAWING TABLE BILD TABLA	INDEX NO. POS. N. INDICE	DISEGNO DRAWING DESSIN ZEICHNUNG DIBUJO	TAVOLA DRAWING TABLE BILD TABLA	INDEX NO. POS. N. INDICE
1513 71301	12	9	8000 08536	22	55	8000 42677	14	27	8000 61313	27	4	8000 69429	27	32	8000 91588	3	28
1519 84701	1	13	8000 10452	8	10	8000 42781	24	8	8000 61314	21	79	8000 69549	19	9	8000 92414	32	9
1611 08401	13	5	8000 10777	32	3	8000 43928	20	31	8000 61362	28	39	8000 69551	23	22	8000 92433	3	15
60N1 01222	21	78	8000 13346	31	3	8000 43928	22	44	8000 62573	23	30	8000 70024	19	8	8000 92797	31	12
60N1 02482	16	3	8000 17810	20	67	8000 43928	32	18	8000 62725	22	47	8000 70216	14	33	8000 92797	32	11
60N1 02483	12	8	8000 20536	22	14	8000 44240	22	46	8000 62725	7	25	8000 70467	5	20	8000 93072	32	21
60N1 02486	10	4	8000 20536	22	61	8000 44240	29	5	8000 62726	14	6	8000 70550	5	18	8000 94126	30	4
60N1 02487	10	8	8000 21480	25	19	8000 45495	28	9	8000 62726	26	12	8000 70551	5	19	8000 94127	30	5
60N1 02488	10	5	8000 21480	30	24	8000 46893	27	28	8000 62726	27	29	8000 71008	14	9	8000 94128	30	6
60N1 02488	12	6	8000 22271	29	9	8000 47763	11	23	8000 62726	32	15	8000 71009	14	8	8000 95749	1	16
60N1 02488	17	7	8000 22551	26	3	8000 48814	27	23	8000 62727	26	5	8000 71230	5	21	8000 95906	12	11
60N1 02489	17	8	8000 22966	31	23	8000 48814	5	23	8000 62728	14	35	8000 71578	25	7	8000 96828	12	14
60N1 02505	25	14	8000 23374	3	34	8000 49035	32	4	8000 62728	18	1	8000 71621	22	53	8000 96838	31	10
60N1 02559	20	68	8000 28327	14	5	8000 49036	31	4	8000 62728	2	16	8000 71622	22	2	8000 96907	20	11
60N1 04134	28	7	8000 28855	7	11	8000 49654	30	16	8000 62728	25	13	8000 71623	22	19	8000 96908	20	11
60N1 07335	25	16	8000 28959	17	15	8000 50453	18	13	8000 62728	27	35	8000 72641	19	10	8000 96928	31	11
60N4 02487	11	13	8000 29089	5	12	8000 53155	21	76	8000 62728	5	22	8000 72868	22	42	8000 96933	31	19
60N4 07335	28	13	8000 29171	11	5	8000 53259	25	18	8000 62728	9	6	8000 72869	22	41	8000 96938	32	12
61N1 15062	20	73	8000 31378	5	7	8000 53259	26	33	8000 62729	21	62	8000 73140	20	5	8000 96940	32	19
61N1 15062	26	6	8000 31748	11	18	8000 53259	30	20	8000 62729	27	14	8000 73500	7	9	8000 96941	22	50
62N1 15548	27	39	8000 31748	3	8	8000 55134	23	33	8000 62729	30	37	8000 73500	8	12	8000 96944	22	18
62N1 15549	19	11	8000 32064	24	14	8000 55134	28	11	8000 62730	7	24	8000 73832	22	64	8000 97219	25	10
63N016349	5	8	8000 32065	24	9	8000 55241	26	11	8000 62731	22	45	8000 74016	22	38	8000 97219	26	27
64N1 20068	20	12	8000 32065	24	16	8000 55902	26	4	8000 62733	21	65	8000 74842	21	87	8000 97219	30	14
66N0 21201	17	14	8000 32388	22	56	8000 55903	26	13	8000 62795	22	43	8000 75160	22	51	8000 98196	16	23
66N0 21206	13	20	8000 33373	20	20	8000 56444	12	15	8000 62796	20	19	8000 75166	22	39	8000 98209	25	6
66N0 21208	13	13	8000 36137	16	4	8000 56444	16	13	8000 62796	21	67	8000 76283	22	11	8000 98215	16	5
66N0 21208	6	10	8000 36137	22	40	8000 56444	20	71	8000 63312	20	39	8000 79015	1	11	8000 98250	16	103
66N0 21247	15	12	8000 36380	13	3	8000 56444	26	36	8000 66238	28	8	8000 79066	26	22	8000 98268	16	30
66N0 21257	9	4	8000 36380	17	2	8000 56462	18	9	8000 66525	14	30	8000 79066	30	22	8000 98272	16	36
66N0 21258	7	12	8000 36786	11	4	8000 56767	32	28	8000 67440	28	5	8000 79099	25	23	8000 98491	23	6
66N0 21270	31	22	8000 37745	28	10	8000 57155	25	12	8000 67545	9	13	8000 79099	30	7	8000 98496	23	13
66N0 21272	32	24	8000 37745	28	21	8000 57155	26	26	8000 67700	28	37	8000 79790	32	28	8000 98497	23	14
66N0 21310	14	14	8000 37745	28	29	8000 57155	30	23	8000 67997	22	57	8000 84938	31	13	8000 98498	23	15
66N0 21312	14	16	8000 38287	13	2	8000 59289	22	24	8000 67997	28	26	8000 87243	20	25	8000 98499	23	17
66N0 21326	15	8	8000 40718	19	3	8000 59801	18	2	8000 69056	20	3	8000 87736	21	71	8000 98504	23	16
66N0 21326	15	19	8000 40924	11	2	8000 59802	18	4	8000 69056	29	7	8000 87745	21	70	8000 99744	14	34
6BN0 21507	13	4	8000 42022	23	31	8000 59803	18	3	8000 69148	27	15	8000 88231	23	32	8000 99868	12	7
6BN0 A7474	11	10	8000 42022	24	6	8000 60233	21	74	8000 69149	27	7	8000 88818	5	16	8000 A0033	12	10
7640 10002	26	7	8000 42023	24	12	8000 60234	21	75	8000 69150	20	18	8000 89089	23	8	8000 A0080	31	8
8000 01199	11	16	8000 42278	17	9	8000 60873	28	32	8000 69282	22	52	8000 89572	32	26	8000 A0081	31	9
8000 01199	3	25	8000 42676	14	26	8000 60898	20	4	8000 69282	28	2	8000 90485	26	25	8000 A0086	32	7

DISEGNO DRAWING DESSIN ZEICHNUNG DIBUJO	TAVOLA DRAWING TABLE BILD TABLA	INDEX NO. POS. N. INDICE	DISEGNO DRAWING DESSIN ZEICHNUNG DIBUJO	TAVOLA DRAWING TABLE BILD TABLA	INDEX NO. POS. N. INDICE	DISEGNO DRAWING DESSIN ZEICHNUNG DIBUJO	TAVOLA DRAWING TABLE BILD TABLA	INDEX NO. POS. N. INDICE	DISEGNO DRAWING DESSIN ZEICHNUNG DIBUJO	TAVOLA DRAWING TABLE BILD TABLA	INDEX NO. POS. N. INDICE	DISEGNO DRAWING DESSIN ZEICHNUNG DIBUJO	TAVOLA DRAWING TABLE BILD TABLA	INDEX NO. POS. N. INDICE	DISEGNO DRAWING DESSIN ZEICHNUNG DIBUJO	TAVOLA DRAWING TABLE BILD TABLA	INDEX NO. POS. N. INDICE
8000 A0575	3	37	8000 A5630	16	43	8000 A6362	3	22	8000 A6954	2	17	8000 A7017	11	15	8000 A7129	15	28
8000 A0671	18	15	8000 A5631	16	44	8000 A6364	3	16	8000 A6955	8	6	8000 A7019	11	6	8000 A7143	30	17
8000 A0693	32	29	8000 A5632	16	45	8000 A6365	3	19	8000 A6956	6	3	8000 A7020	11	21	8000 A7144	30	21
8000 A0931	30	19	8000 A5633	16	46	8000 A6366	3	21	8000 A6958	8	15	8000 A7021	11	22	8000 A7145	30	38
8000 A0932	30	18	8000 A5634	16	51	8000 A6551	3	18	8000 A6960	8	16	8000 A7022	11	3	8000 A7287	15	1
8000 A1138	30	26	8000 A5635	16	52	8000 A6552	3	17	8000 A6965	6	7	8000 A7023	11	1	8000 A7288	15	2
8000 A1139	30	27	8000 A5636	16	55	8000 A6553	3	13	8000 A6966	9	5	8000 A7025	19	13	8000 A7289	15	3
8000 A1239	29	3	8000 A5637	16	83	8000 A6554	14	1	8000 A6967	7	5	8000 A7031	3	27	8000 A7290	15	7
8000 A1559	1	3	8000 A5638	16	85	8000 A6559	3	30	8000 A6968	7	1	8000 A7032	12	2	8000 A7291	15	10
8000 A1580	1	2	8000 A5639	16	90	8000 A6560	3	26	8000 A6968	8	1	8000 A7033	5	11	8000 A7292	15	11
8000 A1625	1	8	8000 A5641	16	122	8000 A6561	3	14	8000 A6970	7	2	8000 A7034	5	10	8000 A7294	15	13
8000 A1792	25	15	8000 A5643	16	148	8000 A6562	3	29	8000 A6970	8	2	8000 A7037	5	14	8000 A7295	15	14
8000 A2141	3	14	8000 A5644	16	152	8000 A6563	3	32	8000 A6971	7	3	8000 A7038	5	15	8000 A7296	15	25
8000 A2790	26	16	8000 A5645	16	206	8000 A6564	3	35	8000 A6971	8	3	8000 A7039	3	24	8000 A7298	15	22
8000 A2791	26	17	8000 A5646	16	207	8000 A6565	13	18	8000 A6972	7	7	8000 A7042	16	2	8000 A7299	15	21
8000 A2792	26	30	8000 A5647	16	209	8000 A6567	2	4	8000 A6973	7	8	8000 A7045	5	3	8000 A7301	15	20
8000 A2793	26	31	8000 A5648	16	241	8000 A6569	2	6	8000 A6973	8	9	8000 A7046	5	17	8000 A7302	15	15
8000 A2794	26	32	8000 A5649	16	243	8000 A6571	2	7	8000 A6975	7	6	8000 A7048	25	17	8000 A7305	14	21
8000 A3488	14	31	8000 A5650	16	244	8000 A6572	2	8	8000 A6976	9	2	8000 A7061	11	8	8000 A7306	14	22
8000 A3774	19	14	8000 A5651	16	245	8000 A6573	2	9	8000 A6977	12	12	8000 A7077	5	9	8000 A7310	14	18
8000 A3975	25	20	8000 A5652	16	264	8000 A6576	2	10	8000 A6981	7	13	8000 A7078	13	14	8000 A7311	14	19
8000 A3975	26	24	8000 A5653	16	265	8000 A6577	2	11	8000 A6982	7	14	8000 A7079	12	4	8000 A7312	14	15
8000 A4266	12	1	8000 A5678	28	14	8000 A6578	2	12	8000 A6988	8	5	8000 A7080	13	10	8000 A7313	14	25
8000 A4291	26	15	8000 A5961	21	63	8000 A6592	4	2	8000 A6989	8	11	8000 A7081	13	11	8000 A7314	14	7
8000 A4295	16	20	8000 A6056	25	2	8000 A6597	15	24	8000 A6990	10	7	8000 A7082	13	12	8000 A7315	14	10
8000 A4431	24	11	8000 A6057	25	3	8000 A6598	4	3	8000 A6995	9	15	8000 A7083	13	8	8000 A7317	1	7
8000 A4511	14	28	8000 A6207	31	8	8000 A6602	4	1	8000 A6996	9	3	8000 A7084	13	15	8000 A7318	14	4
8000 A4562	28	4	8000 A6208	31	9	8000 A6607	5	1	8000 A6997	9	7	8000 A7085	3	7	8000 A7319	6	1
8000 A4565	30	3	8000 A6209	32	7	8000 A6608	5	5	8000 A6999	9	12	8000 A7087	13	9	8000 A7320	14	11
8000 A4609	27	25	8000 A6340	3	1	8000 A6616	5	4	8000 A7001	9	9	8000 A7088	8	13	8000 A7324	17	11
8000 A4630	25	9	8000 A6342	2	3	8000 A6617	5	2	8000 A7004	10	2	8000 A7092	13	1	8000 A7328	14	3
8000 A5071	23	5	8000 A6344	2	2	8000 A6626	6	4	8000 A7006	11	14	8000 A7099	15	4	8000 A7329	14	2
8000 A5616	16	6	8000 A6350	3	2	8000 A6627	6	6	8000 A7007	11	9	8000 A7100	15	5	8000 A7331	14	20
8000 A5617	16	8	8000 A6351	3	3	8000 A6628	6	5	8000 A7009	11	11	8000 A7100	15	18	8000 A7332	14	17
8000 A5618	16	18	8000 A6352	3	9	8000 A6644	27	30	8000 A7010	10	6	8000 A7101	15	6	8000 A7333	14	23
8000 A5620	16	21	8000 A6353	3	10	8000 A6670	23	3	8000 A7011	11	7	8000 A7112	13	19	8000 A7334	14	24
8000 A5621	16	22	8000 A6356	3	11	8000 A6933	6	2	8000 A7012	11	12	8000 A7112	15	23A	8000 A7336	17	10
8000 A5622	16	24	8000 A6356	3	12	8000 A6934	6	8	8000 A7012	17	6	8000 A7116	15	9	8000 A7337	17	12
8000 A5623	16	25	8000 A6357	2	14	8000 A6939	3	38	8000 A7013	11	20	8000 A7116	15	17	8000 A7338	17	13
8000 A5625	16	37	8000 A6358	2	15	8000 A6940	6	9	8000 A7014	11	17	8000 A7125	15	27	8000 A7339	17	16
8000 A5626	16	38	8000 A6359	3	20	8000 A6950	2	13	8000 A7015	1	1	8000 A7126	15	29	8000 A7344	17	4
8000 A5628	16	40	8000 A6360	16	1	8000 A6954	2	5	8000 A7016	11	19	8000 A7128	15	26	8000 A7345	1	5

DISEGNO DRAWING DESSIN ZEICHNUNG DIBUJO	TAVOLA DRAWING TABLE BILD TABLA	INDEX NO. POS. N. INDICE	DISEGNO DRAWING DESSIN ZEICHNUNG DIBUJO	TAVOLA DRAWING TABLE BILD TABLA	INDEX NO. POS. N. INDICE	DISEGNO DRAWING DESSIN ZEICHNUNG DIBUJO	TAVOLA DRAWING TABLE BILD TABLA	INDEX NO. POS. N. INDICE	DISEGNO DRAWING DESSIN ZEICHNUNG DIBUJO	TAVOLA DRAWING TABLE BILD TABLA	INDEX NO. POS. N. INDICE	DISEGNO DRAWING DESSIN ZEICHNUNG DIBUJO	TAVOLA DRAWING TABLE BILD TABLA	INDEX NO. POS. N. INDICE	DISEGNO DRAWING DESSIN ZEICHNUNG DIBUJO	TAVOLA DRAWING TABLE BILD TABLA	INDEX NO. POS. N. INDICE
8000 A7346	17	5	8000 B1693	21	45	8000 H0716	33	8	80A0 66973	7	21	8A00 71620	22	13	8AA0 59433	20	38
8000 A7347	17	1	8000 B1694	21	44	8000 H0732	33	4	80A0 89953	20	9	8A00 71621	22	53	8AA0 A0872	18	19
8000 A7348	15	16A	8000 B1747	20	75	8000 H0733	33	5	80A0 89962	20	10	8A00 76055	26	7	8AB0 53504	31	6
8000 A7592	21	68	8000 B1920	23	11	8000 H0771	30	11	80A0 99619	22	3	8A00 84658	21	86	8B00 13332	13	17
8000 A7593	21	69	8000 B1922	23	18	8000 H0847	33	1	80A0 A0633	21	85	8A00 87717	21	64	8B00 26846	32	10
8000 A7633	26	9	8000 B1923	23	19	8000 H0884	25	4	80A0 A4198	27	6	8A00 92249	19	15	8B00 43715	18	7
8000 A7634	26	1	8000 B5895	13	16	8000 H0885	25	8	80A0 A4610	27	31	8A00 92986	31	15	8B00 96932	31	18
8000 A7635	26	10	8000 H0001	23	21	8000 H1051	23	9	80A0 A6994	9	1	8A00 93036	30	8	8B00 98186	16	27
8000 A7729	29	12	8000 H0002	2	1	8000 H1055	23	34	80A0 A6998	9	11	8A00 96930	31	21	8B00 99475	18	11
8000 A8278	28	6	8000 H0007	1	17	8000 H1056	23	35	80A0 A7000	9	8	8A00 96937	32	8	8B00 A0680	28	27
8000 A8421	23	24	8000 H0008	1	18	8000 H1069	21	11	80A0 A7002	10	1	8A00 98275	16	29	8B00 A2141	3	14
8000 A8421	28	38	8000 H0009	1	20	8000 H1071	21	21	80A0 A8481	21	83	8A00 99475	18	18	8B00 A6561	3	14
8000 A8423	21	84	8000 H0010	20	7	8000 H1072	21	43	80A0 A8482	21	82	8A00 A0085	32	6	8B00 A6576	2	10
8000 A8423	27	33	8000 H0015	29	17	8000 H1073	21	48	80A0 B0245	20	15	8A00 A0669	18	14	8B00 A7126	15	29
8000 A8935	12	3	8000 H0016	18	16	8000 H1074	29	6	80A0 B0246	26	35	8A00 A0902	19	17	8B00 A8421	19	7
8000 A9227	32	28	8000 H0017	18	17	8000 H1412	26	38	80A0 H1016	7	22	8A00 A2141	3	14	8B00 A8421	27	11
8000 A9347	30	1	8000 H0054	19	5	8000 H1421	29	1	80B0 69429	20	72	8A00 A3485	14	32	8B00 A8423	27	54
8000 A9349	30	9	8000 H0055	19	2	8000 H1422	29	2	80B0 A3612	25	1	8A00 A4092	21	80	8C00 34292	14	13
8000 A9350	30	39	8000 H0056	28	1	8000 H1423	29	2	80B0 A6556	3	23	8A00 A5617	16	7	8C00 48590	13	21
8000 A9351	30	2	8000 H0058	12	13	8000 H1439	19	16	80C0 A4216	27	2	8A00 A5879	21	73	8C00 65535	3	31
8000 A9447	26	14	8000 H0064	29	11	8000 H1492	25	21	80C0 B0163	27	10	8A00 A6206	32	6	8C00 69056	21	81
8000 A9448	26	18	8000 H0069	23	1	8000 H1982	25	22	80C0 B0164	27	9	8A00 A6351	10	3	8C00 69429	27	21
8000 A9449	26	37	8000 H0071	23	4	8000 H1984	25	24	80C0 H0705	27	12	8A00 A6561	3	14	8C00 96837	32	16
8000 B0167	27	5	8000 H0074	23	10	8000 H1985	25	25	80C0 H0878	27	3	8A00 A6564	3	33	8C00 A2141	3	14
8000 B0170	27	1	8000 H0075	23	12	8000 H1992	21	18	8661 0191A	27	34	8A00 A6576	2	10	8C00 A6206	32	6
8000 B0171	27	24	8000 H0077	23	20	8000 H1993	21	17	8A00 01815	20	13	8A00 A6628	17	3	8C00 A6561	3	14
8000 B0236	24	4	8000 H0084	29	13	8000 H1994	21	19	8A00 26846	32	20	8A00 A6683	21	77	8D00 62797	24	17
8000 B0239	24	1	8000 H0158	32	17	8000 H2019	16	19	8A00 31386	5	13	8A00 A6978	3	4	8D00 96837	32	16
8000 B0240	24	13	8000 H0192	31	16	8000 H2020	16	26	8A00 37947	19	12	8A00 A7085	3	6	8D00 A2141	3	14
8000 B0241	24	5	8000 H0195	32	14	8000 H2021	16	39	8A00 42700	14	29	8A00 A7112	13	19	8D00 A6561	3	14
8000 B0263	29	10	8000 H0255	28	25	8000 H2022	16	42	8A00 55241	31	17	8A00 A7112	15	23	8E00 61121	20	66
8000 B0288	24	3	8000 H0256	28	24	8000 H2023	16	96	8A00 56768	32	27	8A00 A7126	15	29	8E00 67997	27	27
8000 B0385	3	36	8000 H0260	18	6	8000 H2024	16	123	8A00 59434	20	40	8A00 A7325	14	12	8E00 79785	32	27
8000 B0575	19	4	8000 H0262	18	5	8000 H2025	16	256	8A00 61362	28	28	8A00 A7348	15	16	8E00 99475	19	1
8000 B0647	28	19	8000 H0298	33	6	8000 H2026	23	2	8A00 62733	30	12	8A00 A7348	15	23A	8E00 A2141	3	14
8000 B0841	20	70	8000 H0301	33	7	8000 H2027	23	7	8A00 65844	5	6	8A00 A8421	19	6	8E00 A6561	3	14
8000 B1057	28	3	8000 H0311	33	2	800056377	30	40	8A00 65847	7	10	8A00 A8423	28	18	8E00 A9226	32	27
8000 B1166	22	15	8000 H0311	33	3	8000A6978	3	5	8A00 65847	8	8	8A00 B0240	24	18	8F00 43716	18	8
8000 B1305	29	15	8000 H0474	28	22	8000H0473	28	23	8A00 66525	9	10	8A00 B0439	21	66	8F00 94010	28	20
8000 B1307	29	14	8000 H0680	22	1	8000H0643	7	20	8A00 67545	29	8	8A00 B1162	26	23	8F00 96837	32	16
8000 B1530	21	88	8000 H0709	20	2	800H 0261	18	10	8A00 69125	26	2	8A00 H0023	20	1	8F00 A2141	3	14
8000 B1610	18	12	8000 H0715	33	9	80A0 42349	28	16	8A00 69315	21	72	8AA0 58930	32	5	8F00 A6561	3	14

DISEGNO DRAWING DESSIN ZEICHNUNG DIBUJO	TAVOLA DRAWING TABLE BILD TABLA	INDEX NO. POS. N. INDICE	DISEGNO DRAWING DESSIN ZEICHNUNG DIBUJO	TAVOLA DRAWING TABLE BILD TABLA	INDEX NO. POS. N. INDICE	DISEGNO DRAWING DESSIN ZEICHNUNG DIBUJO	TAVOLA DRAWING TABLE BILD TABLA	INDEX NO. POS. N. INDICE	DISEGNO DRAWING DESSIN ZEICHNUNG DIBUJO	TAVOLA DRAWING TABLE BILD TABLA	INDEX NO. POS. N. INDICE	DISEGNO DRAWING DESSIN ZEICHNUNG DIBUJO	TAVOLA DRAWING TABLE BILD TABLA	INDEX NO. POS. N. INDICE	DISEGNO DRAWING DESSIN ZEICHNUNG DIBUJO	TAVOLA DRAWING TABLE BILD TABLA	INDEX NO. POS. N. INDICE
8G00 A2141	3	14															
8G00 A6561	3	14															
8H00 A2141	3	14															
8H00 A4624	16	28															
8J00 A2141	3	14															
8N00 73458	20	27															
8PA0 67545	7	23															
8PA0 67545	9	14															
8T00 68873	28	12															
Z000 17810	22	21															
Z000 28327	8	14															
Z000 47317	13	7															
Z000 61355	27	13															
Z000 62728	12	5															
Z000 65328	7	4															
Z000 65328	8	4															
Z000 65535	27	8															
ZA00 28327	8	7															
ZB00 67545	7	17															
ZB00 69056	13	6															
ZC00 61121	22	20															
ZD00 67545	7	16															
ZD00 67997	7	15															
ZG00 67545	7	19															
ZU00 67545	7	18															